

NOTICE OF PUBLIC MEETINGS

DATE	TIME	EVENT/PLACE **	PERSONS ATTENDING
Aug 6	8:30 a.m. 1:30 p.m.	BOARD OF ZONING APPEALS STAFF BRIEFING BOARD OF ZONING APPEALS	
Aug 11	7:00 p.m.	PLANNING COMMISSION	
Aug 12	3:00 p.m. 7:00 p.m.	ORDINANCE COMMITTEE BOARD OF SUPERVISORS MEETING	Carter & Shull All Members
Aug 18	10:00 a.m. 10:00 a.m. 5:30 p.m.	HEADWATERS SOIL & WATER CONSERVATION DIST. VALLEY PROGRAM FOR AGING SERVICES COMMUNITY ACTION PROGRAM-STAUTON AUGUSTA AND WAYNESBORO	Carter & Seaton
Aug 19	9:00 a.m. 7:00 p.m.	ELECTORAL BOARD PARKS & RECREATION COMMISSION	Morelli
Aug 20	1:30 p.m.	AUGUSTA COUNTY SERVICE AUTHORITY	Shull
Aug 24	9:30 a.m. 10:30 a.m. 1:30 p.m.	BOARD-ECONOMIC DEVELOPMENT COMMITTEE PUBLIC SAFETY COMMITTEE STAFF BRIEFING	Garber & Wells Wells & Shull All Members
Aug 25	8:30 a.m.	DEPT. OF SOCIAL SERVICES	
Aug 26	7:00 p.m.	BOARD OF SUPERVISORS MEETING	All Members
Aug 27	7:00 p.m.	BROADBAND COMMITTEE	Carter & Morelli
Sept 2	10:00 a.m.	METROPOLITAN PLANNING ORGANIZATION	Seaton
Sept 3	9:30 a.m. 1:30 p.m.	BOARD OF ZONING APPEALS STAFF BRIEFING BOARD OF ZONING APPEALS	
Sept 8	7:00 p.m.	PLANNING COMMISSION	
Sept 9	3:00 p.m. 7:00 p.m.	ORDINANCE COMMITTEE BOARD OF SUPERVISORS	Carter & Shull All Members
Sept 14	1:30 p.m.	COMMUNITY POLICY MANAGEMENT TEAM	
Sept 15	10:00 a.m. 10:00 a.m. 5:30 p.m.	HEADWATERS SOIL & WATER CONSERVATION DIST. VALLEY PROGRAM FOR AGING SERVICES COMMUNITY ACTION PROGRAM-STAUTON AUGUSTA WAYNESBORO	Carter & Seaton
Sept 16	7:00 p.m.	PARKS & RECREATION COMMISSION	Morelli
Sept 17	1:30 p.m.	AUGUSTA COUNTY SERVICE AUTHORITY	Shull
Sept 21	9:30 a.m. 10:30 a.m. 1:30 p.m. 7:00 p.m.	ECONOMIC DEVELOPMENT COMMITTEE PUBLIC SAFETY COMMITTEE STAFF BRIEFING RECYCLING COMMITTEE	Garber & Wells Wells & Shull All Members Seaton
Sept 22	8:30 a.m. 7:00 p.m.	DEPT OF SOCIAL SERVICES AC EMERGENCY SERVICES OFFICERS ASSOC.	Wells & Shull
Sept 23	7:00 p.m.	BOARD OF SUPERVISORS	All Members
Sept 24	4:00 p.m. 7:00 p.m.	LIBRARY BOARD (Weyers Cave Library) BROADBAND COMMITTEE	Morelli Carter & Morelli

DATE: Aug 6, 2020
H:calendar

****All meetings are at the Government Center unless otherwise noted**

A G E N D A

REGULAR MEETING OF THE AUGUSTA COUNTY BOARD OF SUPERVISORS

WEDNESDAY, AUGUST 12, 2020, at 7:00 p.m.

Board Meeting Room, Government Center, Verona, VA

ITEM NO.	DESCRIPTION
7:00 P.M.	PLEDGE OF ALLEGIANCE
	INVOCATION - Public participation is optional; those who wish to join the Board of Supervisors in prayer are asked to remain standing after the Pledge.
	CRAIGSVILLE TOWN OFFICER RECOGNITION
8-01	<u>HEALTH EQUIPMENT LOAN PROGRAM (SEE ATTACHED)</u> Presentation by Sharon Coplai
8-02	<u>CHURCHVILLE ELEMENTARY SCHOOL INFRASTRUCTURE FUNDING (SEE ATTACHED)</u> Consider funding for steps on embankment. Funding Source: Pastures Infrastructure 8014-107 \$10,200.00
8-03	<u>WILSON MEMORIAL HIGH SCHOOL INFRASTRUCTURE FUNDING (SEE ATTACHED)</u> Consider funding for new concession stand equipment. Funding Source: Wayne Infrastructure 8017-106 \$26,378.75
8-04	<u>STRATEGIC PLAN (SEE ATTACHED)</u> Discuss the need for strategic planning process for the County.
8-05	<u>BROADBAND GRANT (SEE ATTACHED)</u> Consider local match for VATI 2021 broadband grant.
8-06	<u>RECORDATION TAX (SEE ATTACHED)</u> Consider resolution to reinstate recordation tax that was eliminated for localities (HB 1414/SB 890 and HB 1726/SB 1038)
8-07	<u>125 E. CRAIG STREET, CRAIGSVILLE, VA (SEE ATTACHED)</u> Consider acceptance of donation of real property.

- 8-08 **WAIVERS (SEE ATTACHED)**
**** Previously tabled on July 22, 2020 ****
Consider a waiver request from the requirement to extend the public street from Brad Long.
- 8-09 **CONSENT AGENDA (SEE ATTACHED)**
8-09.1 **MINUTES**
Consider minutes of the following meetings:
• Regular Meeting, Wednesday, June 10, 2020
• Special Worksession-Solar, Wednesday, June 17, 2020
• Staff Briefing, Monday, June 22, 2020
- 8-09.2 **CLAIMS**
Consider claims paid since July 01, 2020
- (END OF CONSENT AGENDA)**
- 8-10 **MATTERS TO BE PRESENTED BY THE PUBLIC**
- 8-11 **MATTERS TO BE PRESENTED BY THE BOARD**
- 8-12 **MATTERS TO BE PRESENTED BY STAFF**
- 8-13 **CLOSED SESSION (SEE ATTACHED)**

Augusta County Board of Supervisors-- Staff Briefing

Health Equipment Loan Program (HELP)

23 March 2020

Background

- **The Health Equipment Loan Program (HELP) is a charitable Christian organization located in Churchville that is dedicated to recycling gently used donated durable medical equipment; evaluating, restoring and sanitizing it prior to placing into inventory for loaning to those in need.**
- **Vision: anyone living in the Staunton, Waynesboro and Augusta County area that is in need of durable medical equipment to insure health and safety within their home will have access to such equipment on a no-cost loaner basis.**
- **Mission: to provide no-cost loans of medical equipment to those in need**
- **Goals:**
 - **Meet the health equipment needs of our community without the delays and costs associated with acquiring non-covered, or poorly covered, home medical equipment.**
 - **Reduce the physical, financial and emotional burden of care for families caring for loved ones at home.**
 - **Assist in the grieving process by accepting equipment no longer in use due to the death of a loved one.**
 - **Decrease the economic and environmental waste of abandoned or discarded equipment by recycling through our program.**
- **Opened September 2014. Started with ~300 items of gently-used medical equipment donations. Now have over 3500 items (e.g. walkers, bedside commodes, tub benches, ramps, transport chairs) and numerous disposable supplies (e.g. incontinence, wound, ostomy, respiratory care) in inventory.**
- **Income from grants and donations cover operating costs that currently do not include any facility overhead due to hosting by local business, Churchville Pump Service.**
 - **Total grant and donation income past 5 years→ \$30,562**
- **Occupying 467 sq feet within the Churchville Pump Service**
- **Volunteer board of directors and staff primarily from the four Churchville churches (n=65) provide over 1500 hours of service annually**
- **Hours of operation/week = 40 (Tues, Thurs and Sat) with each church responsible for one week/month**

County residents served in 2019

- **443 county residents (42% of total served)**
- **Breakdown by district available**

Outcomes

H.E.L.P. Service Years	Families Helped	Durable Medical Items Loaned	Hospital Beds Loaned	Loan Renewals	Total Inventory Count
2015	183	301			483
2016	547	1019	28	61	1135
2017	701	1354	53	123	1678
2018	910	1699	53	290	2410
2019	1068	2129	40	434	3581
Growth Rate Over 5 years	484%	607%	43%	611%	641%

Analysis of the major category of items loaned and disposable supplies provided at no cost in 2019 reflects over \$200,000 in household savings to our community. Monies not spent purchasing or renting durable medical equipment (DME), hospital beds and disposable medical supplies enabled families to better meet household budget demands while allowing the individual to be cared for in the supportive family home environment.

County landfill diversion

Intangible human benefits:

- Compassionate emotional and spiritual support to caregivers impacting on mental health and well-being enabling them to succeed in supporting the transition from medically-supported care to home and community-based care
- Building of community networks and collaborations among support agencies
- Informing the next generation of caregivers through projects with Murphy Deming College of Health Sciences and local scout troops

Current needs

- Facility space: we have outgrown our current location



- Churchville Pump Service is relocating in Sept 2020 with the owner's retirement. Building will be sold.

- H.E.L.P. would like to purchase the building (\$155K assessed value) unless another suitable location can be identified as available at a lower cost (search to date has yielded no alternatives). This would increase our facility square footage from current 467 (which is often only about 10-20 square feet of open floor space!) to 2169 square feet.

Current strategic actions and future plans

- H.E.L.P. has applied for incorporation as a non-profit, then will apply for IRS 501 (c) (3) status independent of current affiliation with Glossbrenner UMC. Will expand grant eligibility and potential donor pool.
- Capital campaign launched.
 - \$16K raised to date.
 - Letter writing campaign to potential donors, medical providers, local businesses, past service recipients
 - Donation jars in local businesses
 - Presentations to local governmental bodies, area churches and civic organizations
 - Several grants submitted with ongoing grant submissions
 - Researching possibility of USDA Rural Development Loan

More information available

Please feel free to request a tour of our facility at 3925 Churchville Ave, Churchville

Facility phone: 540-324-6186

HELP Board President: Stefanie Bartley, 448-4455

www.medicalcloset.org

[www.Facebook/HELPHealthEquipmentLoanProgram](https://www.facebook.com/HELPHealthEquipmentLoanProgram)



FORT CONSTRUCTION, INC

1810 West Beverley Street
Staunton, VA. 24401
Ph. 540-248-2020 - Fax 540-248-2023
fortconstruction@comcast.net

July 15, 2020

Charlie Snyder
Augusta County Schools
Csnyder@augusta.k12.va.us

Re: Churchville Elem. School—80' Steps on embankment

Proposal will include labor, material, and equipment to complete
The following scope of work:

- *Remove fence
- *Cut grade
- *#57 Stone
- *Forming lumber
- *Drill and pin to wall
- *Pour concrete
- *Strip Forms
- *Re-install chain link fence
- *30' 1 1/4" pipe handrail painted black
- *Clean area of debris

Price: \$10,200.00

If you have any questions, please call the office. Thank You.

Sincerely, 

Danny Smith, Project Manager

Accepted By: _____ Date: _____



Kingdom Builders Inc.
General Contracting Framing and Finishing
84 Graber Lane, Waynesboro, VA 22980
(540)949-8612

Estimate of work to be done: ACSB Maintenance Dept.
P.O. Box 960
Verona, VA 24482

Excavation, forming, pouring concrete for steps at Churchville Elementary School	\$11,000.00
Aluminum white handrails for both sets of steps	\$2800.00
Total:	\$13,800.00

We had two other General Contracts come to the site and then declined to give a quote.

Eavers Brothers
PO Box 186
Stuarts Draft, VA 24477
Corey Eavers
540-337-1151

R. L. Flint, JR Inc.
General Contractor
Bo Flint
129 Hunter Lane
Staunton, VA 24401
540-885-4177

WILSON MEMORIAL HIGH SCHOOL

189 Hornet Road • Fishersville, VA 22939
Phone 540-886-4286 Fax 540-886-4611



July 14, 2020

Dr. Scott Seaton
Wayne District Supervisor
Augusta County Board of Supervisors
18 Government Center Lane
Verona, VA 24482

Dr. Seaton:

Greetings, sir.

In response to our phone conversation last week, I have enclosed the quote we have received for new concession stand equipment as it relates to the construction project at *Steve Geiman Stadium*. I hope you will excuse the manner in which I am sending this information to you, as I am doing so remotely from my annual family vacation.

I am not sure how much you may/may not be aware of as it relates to expenses associated with the construction of the new concession stand. Initially, new equipment was to be included as part of the joint financing effort between the Wilson Memorial Booster Club, Wilson Little League Football, Augusta County School Board, and Augusta County Supervisors. When construction bids came in higher than expected, new equipment was cut as part of the cost savings process.

As we prepare for the 2020-21 scholastic year, assuming the current public health situation allows for us to have extracurricular activities in some form this year, we plan to utilize the old concession stand equipment. During this interim period, the Wilson Memorial Athletic Boosters will attempt to raise enough funds to support the purchase of new equipment.

Certainly, if you were able to help with this project, it would take a big weight off of the shoulders of the volunteers associated with the Wilson Memorial Athletic Boosters. Please review the requested equipment, the use of which will be shared by both the high school activities and Wilson Little League Football. If you feel as if this would be a worthy endeavor as it relates to your assistance, I'd appreciate hearing back from you. I am also willing to answer any questions you might have. Certainly, I also understand that the Wayne District might have many items that need your attention, also.

Thank you for your service to our community.

Respectfully,

Craig P. Flesher

Dr. Kelly F. Troxell, Principal
Susan L. Mace, Assistant Principal

Steven D. Hom, Assistant Principal
Craig P. Flesher, Athletic Director / Assistant Principal

Quote



03/05/2020

Project:
SWORTZEL

From:
Cavalier Restaurant Equipment
Deborah Somoza
1221 West Main Street
(804)712-1861 (Cell)
540-943-9543 (Store)
540-943-7025 (Fax)
CAVALIERSOMOZA@AOL.COM

Job Reference Number: 1061

Item	Qty	Description	Sell	Sell Total
1	3 ea	WORK TABLE, STAINLESS STEEL TOP BK Resources Model No. VTTR-9630 Work Table, 96"W x 30"D, 18/430 stainless steel top, with turndown edges front & sides, reinforced with channels, 1-1/2" rear riser, adjustable galvanized undershelf, (6) 1-5/8" dia. galvanized legs, adjustable high-impact corrosion-resistant feet, NSF	\$386.14	\$1,158.42
			ITEM TOTAL:	\$1,158.42
2	1 ea	THREE (3) COMPARTMENT SINK BK Resources Model No. BKS-3-18-12-18L Sink, three compartment, 74-1/2"W x 23-13/16"D x 43-3/4"H overall size, 18" wide x 18" front-to-back x 12" deep compartments, 18" drainboard on left, 9"H backsplash, 8" OC splash mount faucet holes, 1-1/2" rolled edges on front & sides, includes basket drains (BKDR-4), 18/304 stainless steel construction, galvanized steel legs, adjustable high impact corrosion resistant feet, NSF	\$958.27	\$958.27
			ITEM TOTAL:	\$958.27
3	1 ea	REACH-IN REFRIGERATOR True Manufacturing Co., Inc. Model No. T-23-HC Refrigerator, reach-in, one-section, (1) solid door, (3) PVC coated adjustable wire shelves, interior lighting, stainless steel door, stainless steel front, aluminum sides, clear coated aluminum interior with stainless steel floor, 4" castors, R290 Hydrocarbon refrigerant, 1/4 HP, 115v/60/1-ph, 2.2 amps, NEMA 5-15P, cULus, UL EPH Classified, CE, Made in USA, ENERGY STAR® 1 ea NOTE: Commonly stocked model in right and left hinge; verify availability with factory 1 ea Self-contained refrigeration standard 1 ea Warranty - 7 year compressor (self-contained only), please visit www.Truemfg.com for specifics (updated warranty sheet pending from True) 1 ea Warranty - 3 year parts and labor, please visit www.Truemfg.com for specifics 1 ea Door hinged right standard 1 ea 4" stem castors, standard (adds 5" to OA height)	\$2,623.41	\$2,623.41

Item	Qty	Description	Sell	Sell Total
			ITEM TOTAL:	\$2,623.41
4	1 ea	REACH-IN FREEZER  <p>True Manufacturing Co., Inc. Model No. T-23F-HC Freezer, reach-in, one-section, -10°F, (1) solid door, (3) PVC coated adjustable wire shelves, interior lighting, stainless steel door, stainless steel front, aluminum sides, clear coated aluminum interior with stainless steel floor, 4" castors, R290 Hydrocarbon refrigerant, 1/2 HP, 115v/60/1-ph, 3.7 amps, NEMA 5-15P, cULus, UL EPH Classified, Made in USA, ENERGY STAR®</p> <p>1 ea NOTE: Commonly stocked model in right and left hinge; verify availability with factory</p> <p>1 ea Self-contained refrigeration standard</p> <p>1 ea Warranty - 7 year compressor (self-contained only), please visit www.Truemfg.com for specifics (updated warranty sheet pending from True)</p> <p>1 ea Warranty - 3 year parts and labor, please visit www.Truemfg.com for specifics</p> <p>1 ea Door hinged right standard</p> <p>1 ea 4" stem castors, standard (adds 5" to OA height)</p>	\$3,278.06	\$3,278.06
			ITEM TOTAL:	\$3,278.06
5	1 ea	REACH-IN FREEZER  <p>True Manufacturing Co., Inc. Model No. T-49F-HC Freezer, reach-in, two-section, -10°F, (2) stainless steel doors, (6) PVC coated adjustable wire shelves, interior lighting, stainless steel front, aluminum sides, aluminum interior with stainless steel floor, 4" castors, R290 Hydrocarbon refrigerant, 1 HP, 115v/60/1-ph, 9.6 amps, NEMA 5-15P, Made in USA, cULus, UL EPH Classified, ENERGY STAR®</p> <p>1 ea Self-contained refrigeration standard</p> <p>1 ea Warranty - 7 year compressor (self-contained only), please visit www.Truemfg.com for specifics (updated warranty sheet pending from True)</p> <p>1 ea Warranty - 3 year parts and labor, please visit www.Truemfg.com for specifics</p> <p>1 ea Left door hinged left, right door hinged right standard</p> <p>1 ea 4" stem castors, standard (adds 5" to OA height)</p>	\$4,597.02	\$4,597.02
			ITEM TOTAL:	\$4,597.02
6	1 ea	MOBILE HEATED CABINET  <p>Metro Model No. C519-HFC-4 C5™ 1 Series Heated Holding Cabinet, mobile, full height, non-insulated, clear polycarbonate door, removable bottom mount control module, thermostat to 190°F, fixed wire slides on 3" centers (18) 18" x 26" or (34) 12" x 20" x 2-1/2" pan capacity, 5" castors (2 with brakes), aluminum, 120v/60/1-ph, 2000 watts, 16.7 amps, NEMA 5-20P, cULus, NSF</p> <p>1 ea 1 year warranty against manufacturing defects</p>	\$2,101.76	\$2,101.76
			ITEM TOTAL:	\$2,101.76
7	1 ea	ICE MAKER, CUBE-STYLE	\$2,984.38	\$2,984.38

Initial: _____

Page 2 of 4

Item	Qty	Description	Sell	Sell Total
		Manitowoc Model No. IDT0500A Indigo NXT™ Series Ice Maker, cube-style, air-cooled, self-contained condenser, 30"W x 24"D x 21-1/2"H, production capacity up to 520 lb/24 hours at 70°/50° (400 lb AHRI certified at 90°/70°), DuraTech™ exterior, dice size cubes, R410A refrigerant, NSF, cULus, CE, ENERGY STAR®		
	1 ea	WARRANTY-ICE-SC 3 year parts & labor (Machine), 5 year parts & labor (Evaporator), 5 year parts & 3 years labor (Compressor), standard		
	1 ea	(-161) 115v/60/1-ph, 11.5 amps		
	1 ea	DS70 Ice Bin, 30"W x 34"D x 50"H, with side-hinged front-opening door, side grips, 532 lbs. application capacity, AHRI certified 17.9 cu. ft., for top-mounted ice maker, Duratech exterior, NSF	\$1,410.00	\$1,410.00
	1 ea	WARRANTY-BIN/DISP 3 year parts & labor warranty, standard		
	1 ea	Legs, 6" adjustable stainless steel, standard		
			ITEM TOTAL:	\$4,394.38
8	1 ea	GAS FLOOR FRYER Royal Range of California Model No. RFT-50 Fryer, gas, floor model, tube-fired, 50 lb. oil capacity full tank, (3) 38,000 BTU burners, thermostatic control, millivolt temp control with 200° - 400°F range, 6" adjustable legs, stainless steel front and sides, 114,000 BTU, CSA Star, CSA Flame, NSF, Made in USA	\$985.20	\$985.20
	1 ea	One year parts and labor warranty, five year limited warranty on fry tank, standard		
	1 ea	Gas type to be specified		
			ITEM TOTAL:	\$985.20
9	1 ea	GAS COUNTERTOP GRIDDLE Royal Range of California Model No. RMG-72 Griddle, countertop, gas, 72" W cooking surface, 3/4" thick polished steel griddle plate, manual controls, 4" grease trough, stainless steel splashguards, sides & front valve cover, 4" legs, 180,000 BTU, cETLus, NSF, Made in USA	\$3,552.66	\$3,552.66
	1 ea	Two year limited parts and labor warranty, standard		
	1 ea	Gas type to be specified		
	1 ea	RSS-72HD Equipment Stand, 72-1/2" W x 30" D x 22" H, open base, stainless steel construction, for heavy duty line, KD, Made in USA	\$910.57	\$910.57
	1 ea	Casters, set of 6 (3 locking)	\$223.56	\$223.56
			ITEM TOTAL:	\$4,686.79
10	1 ea	FRYER DUMP STATION Royal Range of California Model No. RFT-DS Fryer Drain Station, heavy duty floor model, storage base with drain pan, stainless steel, CSA Star, CSA Flame, NSF, Made in USA	\$1,595.44	\$1,595.44
			ITEM TOTAL:	\$1,595.44
			Total	\$26,378.75

03/05/2020

Acceptance: _____ Date: _____

Printed Name: _____

Project Grand Total: \$26,378.75



Riser Top Work Tables

Stainless Steel Work Tables



Use your smart phone to scan the above QR code to visit our website
www.bk-resources.com



Certifications:



Features:

- Two (2) Sound Deadened Integrally Welded 5" "C" Channels to Reinforce and Maintain Level Working Surface
- Legs 1 5/8" Diameter
- 1 1/2" Splash Riser
- 84" & 96" Tables Have 6 Legs

Options:

- Single & Double Overshelves
- Drawer Assemblies
- Casters
- Upgraded Bullet Feet
- Extra Shelves
- Adjustable Table Mount Pot Rack

Material:

VTTR Series: S/S w/ Galvanized Legs & Undershelf

- T-430 18 ga. Stainless Steel Top
- Galvanized Legs & Adjustable Undershelf
- Adjustable High Impact Corrosion Resistant Feet

SVTR Series: S/S w/ Stainless Steel Legs & Undershelf

- T-430 18 ga. Stainless Steel Top
- Stainless Steel Legs & Adjustable Undershelf
- S/S Bullet Feet

Length	VTTR Series S/S w/ Galv. Legs & Undershelf			SVTR Series S/S w/ S/S Legs & Undershelf		
	T-430 S/S 18" Width	T-430 S/S 24" Width	T-430 S/S 30" Width	T-430 S/S 18" Width	T-430 S/S 24" Width	T-430 S/S 30" Width
24"	VTTR-1824	VTTR-2424	-	SVTR-1824	SVTR-2424	-
30"	VTTR-1830	VTTR-3024	VTTR-3030	SVTR-1830	SVTR-3024	SVTR-3030
36"	VTTR-1836	VTTR-3624	VTTR-3630	SVTR-1836	SVTR-3624	SVTR-3630
48"	VTTR-1848	VTTR-4824	VTTR-4830	SVTR-1848	SVTR-4824	SVTR-4830
60"	VTTR-1860	VTTR-6024	VTTR-6030	SVTR-1860	SVTR-6024	SVTR-6030
72"	VTTR-1872	VTTR-7224	VTTR-7230	SVTR-1872	SVTR-7224	SVTR-7230
84"	VTTR-1884	VTTR-8424	VTTR-8430	SVTR-1884	SVTR-8424	SVTR-8430
96"	VTTR-1896	VTTR-9624	VTTR-9630	SVTR-1896	SVTR-9624	SVTR-9630

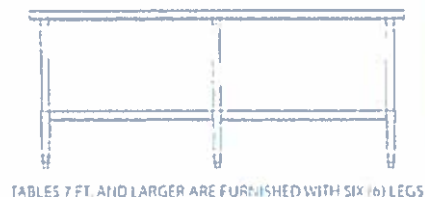
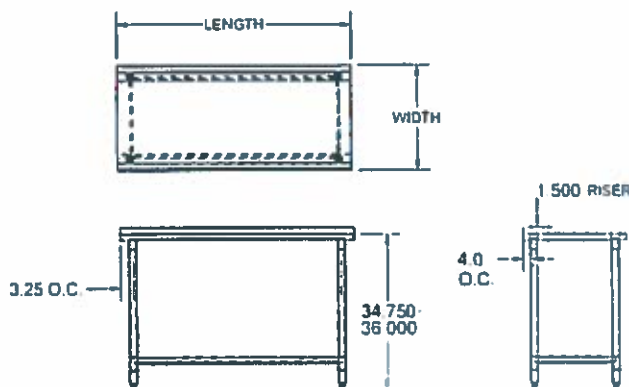

PRODUCT DATA SHEET

BK RESOURCES





Three Compartment - One Drainboard

Stainless Steel Compartment Sinks



Use your smart phone to scan the above QR code to visit our website.
www.bk-resources.com

Certifications:

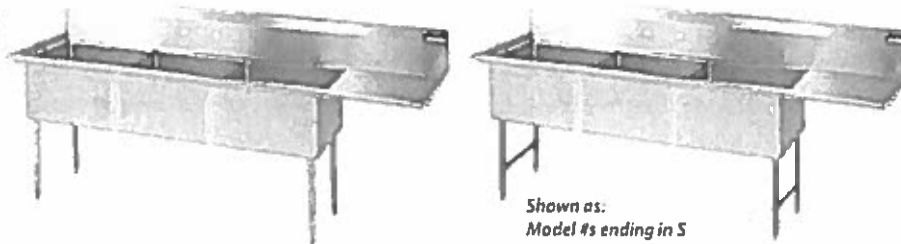

Shown as:
Model #s ending in S

Features:

- 1/4" Pitched Drainboards To Ensure Proper Drainage
- 1 1/2" Rounded Front and Side Edges
- Accommodates 8" On Center Faucets
- Drains Included
- 9" Backsplash

Options:

- Pre-Rinse Units & Faucets
- Lever Drains
- Upgraded Bullet Feet
- Slant Rack Shelf (BK-SSH)
- End Splash (BKS-RES)
- S/S Basket Drain (BKDR-4-304)

Material:

- T-304 18 ga. Stainless Steel Deck & Bowls
- 1 1/2" Galvanized Legs
- Adjustable High Impact Corrosion Resistant Feet

Model #s ending with "S":

- T-304 18 ga. Stainless Steel Deck & Bowls
- Stainless Steel Legs
- Stainless Steel End Bracing
- Adjustable Stainless Steel over Plastic Bullet Feet

** Please specify Left or Right Drainboard*

Part Number	Unit Size (l x w)	Bowl Dim. (l x w x d)	Sets of Faucet Holes	Drainboard Size	Legs
BKS-3-15-14-15L/R	62 ^{1/2"} x 20 ^{11/16"}	15" x 15" x 14"	1	(1)L/R - 15"	Galvanized
BKS-3-15-14-15L/RS	62 ^{1/2"} x 20 ^{11/16"}	15" x 15" x 14"	1	(1)L/R - 15"	Stainless Steel w/ End Bracing
BKS-3-1620-12-18L/R	68 ^{1/2"} x 25 ^{11/16"}	16" x 20" x 12"	1	(1)L/R - 18"	Galvanized
BKS-3-1620-12-18L/RS	68 ^{1/2"} x 25 ^{11/16"}	16" x 20" x 12"	1	(1)L/R - 18"	Stainless Steel w/ End Bracing
BKS-3-18-12-18L/R	74 ^{1/2"} x 23 ^{11/16"}	18" x 18" x 12"	1	(1)L/R - 18"	Galvanized
BKS-3-18-12-18L/RS	74 ^{1/2"} x 23 ^{11/16"}	18" x 18" x 12"	1	(1)L/R - 18"	Stainless Steel w/ End Bracing
BKS-3-1824-14-24L/R	80 ^{1/2"} x 29 ^{11/16"}	18" x 24" x 14"	1	(1)L/R - 24"	Galvanized
BKS-3-1824-14-24L/RS	80 ^{1/2"} x 29 ^{11/16"}	18" x 24" x 14"	1	(1)L/R - 24"	Stainless Steel w/ End Bracing
BKS-3-24-14-24L/R	98 ^{1/2"} x 29 ^{11/16"}	24" x 24" x 14"	2	(1)L/R - 24"	Galvanized
BKS-3-24-14-24L/RS	98 ^{1/2"} x 29 ^{11/16"}	24" x 24" x 14"	2	(1)L/R - 24"	Stainless Steel w/ End Bracing

PRODUCT DATA SHEET

BK RESOURCES





Three Compartment - One Drainboard

Stainless Steel Compartment Sinks

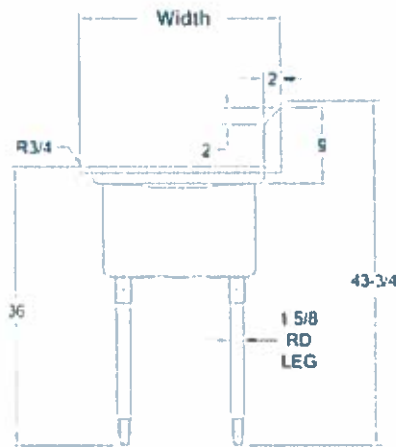
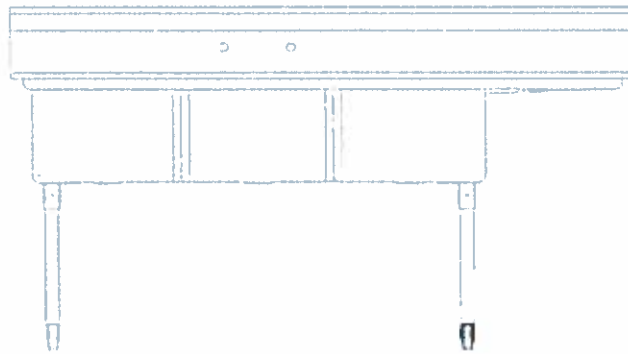
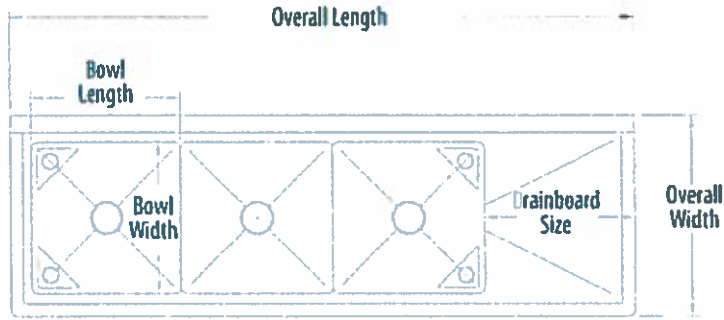

PRODUCT DATA SHEET

BK RESOURCES



 TRUE MANUFACTURING CO., INC. U.S.A. FOODSERVICE DIVISION 2001 East Terra Lane • O'Fallon, Missouri 63366-4434 • (636)240-2400 Fax (636)272-2408 • Toll Free (800)325-6152 • Intl Fax# (001)636-272-7546 Parts Dept. (800)424-TRUE • Parts Dept. Fax# (636)272-9471 • www.truemfg.com	Project Name: _____ Location: _____ Item #: _____ Qty: _____ Model #: _____	A/A # S/S #
	Model: T-23-HC	

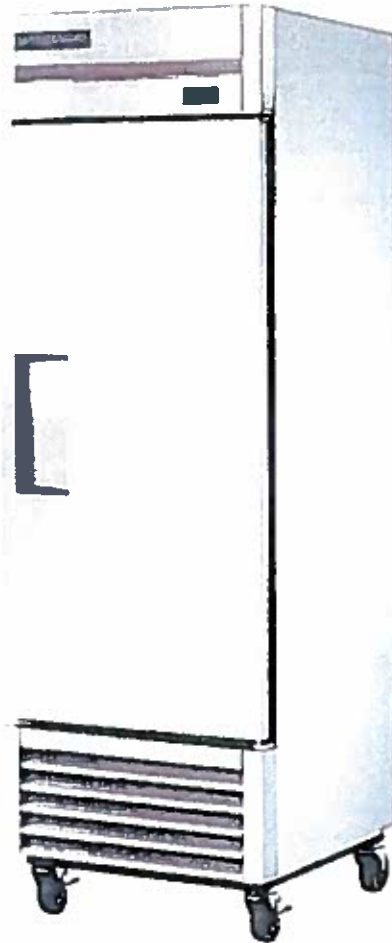

T-23-HC

- ▶ True's solid door reach-ins are designed with enduring quality that protects your long term investment.
- ▶ Designed using the highest quality materials and components to provide the user with colder product temperatures, lower utility costs, exceptional food safety and the best value in today's food service marketplace.
- ▶ Factory engineered, self-contained capillary tube system using environmentally friendly R290 hydro carbon refrigerant that has zero (0) ozone depletion potential (ODP), & three (3) global warming potential (GWP).
- ▶ High capacity, factory balanced refrigeration system that maintains cabinet temperatures of 33°F to 38 F (5°C to 3.3°C) for the best in food preservation.
- ▶ Stainless steel solid door and front. The finest stainless available with higher tensile strength for fewer dents and scratches.
- ▶ Adjustable, heavy duty PVC coated shelves.
- ▶ Positive seal self-closing door. Lifetime guaranteed door hinges and torsion type closure system.

Bottom mounted units feature

- ▶ "No stoop" lower shelf.
- ▶ Storage on top of cabinet.
- ▶ Compressor performs in coolest, most grease free area of kitchen.
- ▶ Easily accessible condenser coil for cleaning.

ROUGH-IN DATA

Chart dimensions rounded up to the nearest 1/4" (m millimeters rounded up to the next whole number) Specifications subject to change without notice

Model	Doors	Shelves	Cabinet Dimensions (inches) (mm)			HP	Voltage	Amps	NEMA Config.	Cord Length (total ft.) (total m)	Crated Weight (lbs.) (kg)
			L	D	H*						
T-23-HC	1	3	27	29½	78¾	¼	115/60/1	2.2	5-15P	9	285
			686	750	1991	¼	230-240/50/1	1.2	▲	2.74	130

* Height does not include 5" (127 mm) for castors or 6" (153 mm) for optional legs.

▲ Plug type varies by country

    	APPROVALS:	AVAILABLE AT:
6/18-A Printed in U.S.A.		

Model:
T-23-HC

T-Series:
Reach-In Solid Swing Door Refrigerator with
Hydrocarbon Refrigerant

True®

STANDARD FEATURES

DESIGN

- True's commitment to using the highest quality materials and optimized refrigeration systems provides the user with colder product temperatures, lower utility costs, exceptional food safety and the best value in today's food service marketplace.

REFRIGERATION SYSTEM

- Factory engineered, self-contained, capillary tube system using environmentally friendly R290 hydrocarbon refrigerant that has zero (0) ozone depletion potential (ODP), & three (3) global warming potential (GWP).
- High capacity, factory balanced refrigeration system that maintains cabinet temperatures of 33°F to 38°F (5°C to 3.3°C) for the best in food preservation.
- State of the art, electronically commutated evaporator and condenser fan motors. ECM motors operate at higher peak efficiencies and move a more consistent volume of air which produces less heat, reduces energy consumption and provides greater motor reliability.
- Bottom mounted condensing unit positioned for easy maintenance. Compressor runs in coolest and most grease free area of the kitchen. Allows for storage area on top of unit.

CABINET CONSTRUCTION

- Exterior - Stainless steel front. Anodized quality aluminum ends. Corrosion resistant GalFan coated steel back.

- Interior - attractive, NSF approved, clear coated aluminum liner. Stainless steel floor with coved corners.
- Insulation - entire cabinet structure and solid door are foamed-in-place using a high density, polyurethane insulation that has zero ozone depletion potential (ODP) and zero global warming potential (GWP).
- Welded, heavy duty steel frame rail, black powder coated for corrosion protection.
- Frame rail fitted with 4" (102 mm) diameter stem castors - locks provided on front set.

DOOR

- Stainless steel exterior with clear aluminum liner to match cabinet interior. Door extends full width of cabinet shell. Door locks standard.
- Lifetime guaranteed recessed door handle. Door fitted with 12" (305 mm) long recessed handle that is foamed-in-place with a sheet metal interlock to ensure permanent attachment.
- Positive seal self-closing door. Lifetime guaranteed door hinges and torsion type closure system.
- Magnetic door gasket of one piece construction, removable without tools for ease of cleaning.

SHELVING

- Three (3) adjustable, heavy duty PVC coated wire shelves 22 1/8"L x 23 1/4"D (582 mm x 591 mm). Four (4) chrome plated shelf clips included per shelf.

- Shelf support pilasters made of same material as cabinet interior, shelves are adjustable on 1/2" (13 mm) increments.

LIGHTING

- Interior lighting - safety shielded. Lights activated by rocker switch mounted above door.

MODEL FEATURES

- Exterior temperature display.
- Evaporator is epoxy coated to eliminate the potential of corrosion.

ELECTRICAL

- Unit completely pre-wired at factory and ready for final connection to a 115/60/1 phase, 15 amp dedicated outlet. Cord and plug set included.



115/60/1
NEMA-5-15R

OPTIONAL FEATURES/ACCESSORIES

Upcharge and lead times may apply.

- ┆ 230 - 240V / 50 Hz.
- ┆ 6" (153 mm) standard legs.
- ┆ 6" (153 mm) seismic/flanged legs
- ┆ Alternate door hinging (factory installed)
- ┆ Additional shelves.
- ┆ Half door bun tray racks. Each holds up to eleven 18"L x 26"D (458 mm x 661 mm) sheet pans (sold separately)
- ┆ Full door bun tray rack. Holds up to twenty-two 18"L x 26"D (458 mm x 661 mm) sheet pans (sold separately).

PLAN VIEW

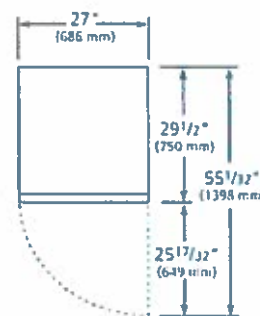
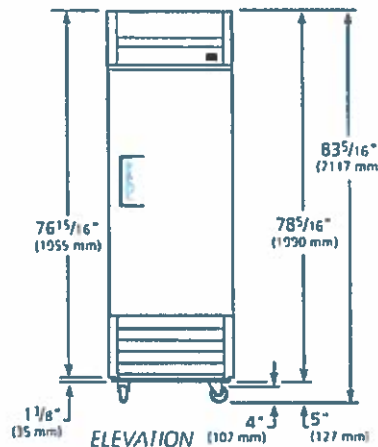

WARRANTY

Three year warranty on all parts and labor and an additional 2 year warranty on compressor. (U.S.A. only)

METRIC DIMENSIONS ROUNDED UP TO THE NEAREST WHOLE MILLIMETER

SPECIFICATIONS SUBJECT TO CHANGE WITHOUT NOTICE

Model	Elevation	Right	Plan	3D	Back
T-23-HC	TFEY53E	TFEY03S	TFEY03P	TFEY633	

TRUE MANUFACTURING CO., INC.

2001 East Terra Lane • O'Fallon, Missouri 63366-4434 • (636)240-2400 • Fax (636)272-2408 • Toll Free (800)325-6152 • Int'l. Fax# (001)636-272-7546 • www.truemfg.com

TRUE FOOD SERVICE EQUIPMENT, INC. 2001 East Terra Lane • O'Fallon, Missouri 63366-4434 • (636)240-2400 Fax (636)272-2408 • Toll Free (800)325-6152 • Intl Fax# (001)636-272-7546 Parts Dept. (800)424-TRUE • Parts Dept. Fax# (636)272-9471 • www.truefmg.com	Project Name: _____ Location: _____ Item #: _____ Qty: _____ Model #: _____	AIA # _____ SIS # _____
	Model: T-23F-HC	
	T-Series: <i>Reach-In Solid Swing Door Freezer with Hydrocarbon Refrigerant</i>	

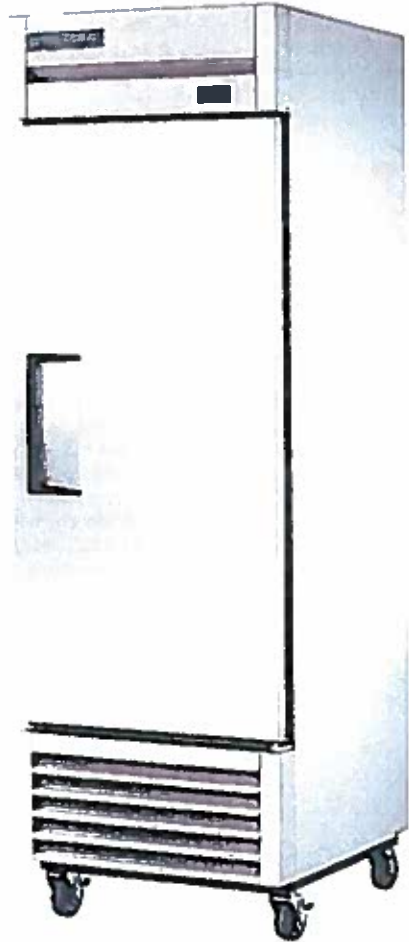

T-23F-HC

- ▶ True's solid door reach-in's are designed with enduring quality that protects your long term investment.
- ▶ Designed using the highest quality materials and components to provide the user with colder product temperatures, lower utility costs, exceptional food safety and the best value in today's food service marketplace.
- ▶ Extra large evaporator coil balanced with higher horsepower compressor and large condenser maintains -10°F (-23.3°C) cabinet temperatures. Ideally suited for both frozen foods and ice cream.
- ▶ Stainless steel solid door and front. The very finest stainless with higher tensile strength for fewer dents and scratches.
- ▶ Adjustable, heavy duty PVC coated shelves.
- ▶ Positive seal self-closing door. Lifetime guaranteed door hinges and torsion type closure system.
- ▶ Automatic defrost system time-initiated, temperature-terminated. Saves energy consumption and provides shortest possible defrost cycle.

Bottom mounted units feature:

- ▶ "No stoop" lower shelf.
- ▶ Storage on top of cabinet.
- ▶ Compressor performs in coolest, most grease free area of kitchen
- ▶ Easily accessible condenser coil for cleaning.

ROUGH-IN DATA

Specifications subject to change without notice
 Chart dimensions rounded up to the nearest 1/8" (millimeters rounded up to next whole number)

Model	Doors	Shelves	Cabinet Dimensions (inches)			HP	Voltage	Amps	NEMA Config.	Cord Length (total ft.)	Crated Weight (lbs.)
			(mm)	L	D						
T-23F-HC	1	3	27	29½	78¾	½	115/60/1	3.7	5-15P	9	295
			686	750	1991						

* Height does not include 5" (127 mm) for castors or 6" (153 mm) for optional legs.

▲ Plug type varies by country.

	APPROVALS: _____	AVAILABLE AT: _____
9/17 Printed in U.S.A.		

Model:
T-23F-HC

T-Series:
Reach-In Solid Swing Door Freezer with Hydrocarbon Refrigerant



STANDARD FEATURES

DESIGN

- True's commitment to using the highest quality materials and oversized refrigeration systems provides the user with colder product temperatures, lower utility costs, exceptional food safety and the best value in today's food service marketplace.

REFRIGERATION SYSTEM

- Factory engineered, self-contained, capillary tube system using environmentally friendly R290 hydro carbon refrigerant that has zero (0) ozone depletion potential (ODP), & three (3) global warming potential (GWP).
- Extra large evaporator coil balanced with higher horsepower compressor and large condenser, maintains -10°F (-23.3°C). Ideally suited for both frozen foods and ice cream.
- State of the art, electronically commutated evaporator and condenser fan motors. ECM motors operate at higher peak efficiencies and move a more consistent volume of air which produces less heat, reduces energy consumption and provides greater motor reliability.
- Bottom mounted condensing unit positioned for easy cleaning. Compressor runs in coolest and most grease free area of the kitchen. Allows for storage area on top of unit.
- Automatic defrost system time-initiated, temperature-terminated. Saves energy consumption and provides shortest possible defrost cycle.

CABINET CONSTRUCTION

- Exterior - Stainless steel front. Anodized quality aluminum ends. Corrosion resistant GalFan coated steel back.

- Interior - attractive, NSF approved, clear coated aluminum liner. Stainless steel floor with coved corners.
- Insulation - entire cabinet structure and solid door are foamed-in-place using a high density, polyurethane insulation that has zero ozone depletion potential (ODP) and zero global warming potential (GWP).
- Welded, heavy duty steel frame rail, black powder coated for corrosion protection.
- Frame rail fitted with 4" (102 mm) diameter stem castors - locks provided on front set.

DOOR

- Stainless steel exterior with clear aluminum liner to match cabinet interior. Door extend full width of cabinet shell. Door lock standard.
- Lifetime guaranteed recessed door handle. Door fitted with 12" (305 mm) long recessed handle that is foamed-in-place with a sheet metal interlock to ensure permanent attachment.
- Positive seal self-closing door. Lifetime guaranteed door hinges and torsion type closure system.
- Magnetic door gasket of one piece construction, removable without tools for ease of cleaning.

SHELVING

- Three (3) adjustable, heavy duty PVC coated wire shelves 22 1/4" L x 23 1/4" D (582 mm x 591 mm). Four (4) chrome plated shelf clips included per shelf.
- Shelf support pilasters made of same material as cabinet interior, shelves are adjustable on 1/2" (13 mm) increments.

LIGHTING

- Interior lighting - safety shielded. Lights activated by rocker switch mounted above door.

MODEL FEATURES

- Exterior temperature display.
- Evaporator is epoxy coated to eliminate the potential of corrosion.
- Rear airflow guards prevent product from blocking optimal airflow.
- NSF/ANSI Standard 7 compliant for open food product.

ELECTRICAL

- Unit completely pre-wired at factory and ready for final connection to a 115/60/1 phase, 15 amp dedicated outlet. Cord and plug set included



115/60/1
NEMA-5-15R

OPTIONAL FEATURES/ACCESSORIES

- Upcharge and lead times may apply.
- ┆ 230 - 240V / 50 Hz.
 - ┆ 6" (153 mm) standard legs.
 - ┆ 6" (153 mm) seismic/flanged legs.
 - ┆ Alternate door hinging (factory installed)
 - ┆ Novelty baskets.
 - ┆ Additional shelves.
 - ┆ Half door bun tray racks. Each holds up to eleven 18" L x 26" D (458 mm x 661 mm) sheet pans (sold separately) (airflow guards need to be removed)
 - ┆ Full door bun tray rack. Holds up to twenty-two 18" L x 26" D (458 mm x 661 mm) sheet pans (sold separately) (airflow guards need to be removed).

PLAN VIEW

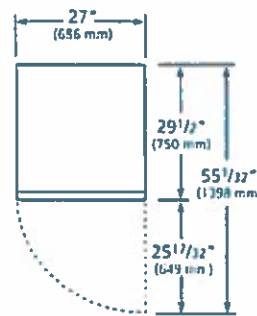
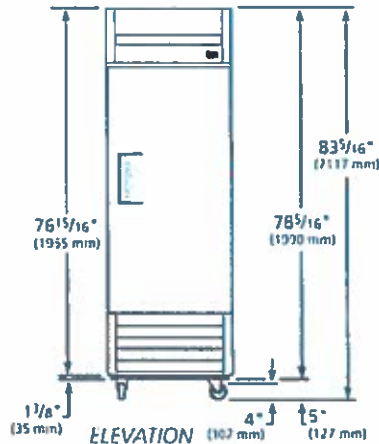

WARRANTY*
Three year warranty on all parts and labor and an additional 2 year warranty on compressor. (U.S.A. only)

METRIC DIMENSIONS ROUNDED UP TO THE NEAREST WHOLE MILLIMETER
SPECIFICATIONS SUBJECT TO CHANGE WITHOUT NOTICE

	Model	Elevation	Right	Plan	3D	Back
	T-23F-HC	TFEY53E	TFEY03S	TFEY03P	TFEY633	

*RESIDENTIAL APPLICATIONS: True assumes no liability for parts or labor coverage for 100% percent failure factory defect or any other damages for units installed in non-commercial food service or residential applications

TRUE FOOD SERVICE EQUIPMENT

2001 East Terra Lane • O'Fallon, Missouri 63366-4434 • (636)240-2400 • Fax (636)272-2408 • Toll Free (800)325-6152 • Intl. Fax# (001)636-272-7546 • www.truemf.com

 TRUE FOOD SERVICE EQUIPMENT, INC. 2001 East Terra Lane • O'Fallon, Missouri 63366-4434 • (636)240-2400 Fax (636)272-2408 • Toll Free (800)325-6152 • Intl Fax# (001)636-272-7546 Parts Dept. (800)424-TRUE • Parts Dept. Fax# (636)272-9471 • www.truemfg.com	Project Name: _____ Location: _____ Item #: _____ Qty: _____ Model #: _____	AIA # _____ SIS # _____
	Model: T-49F-HC	

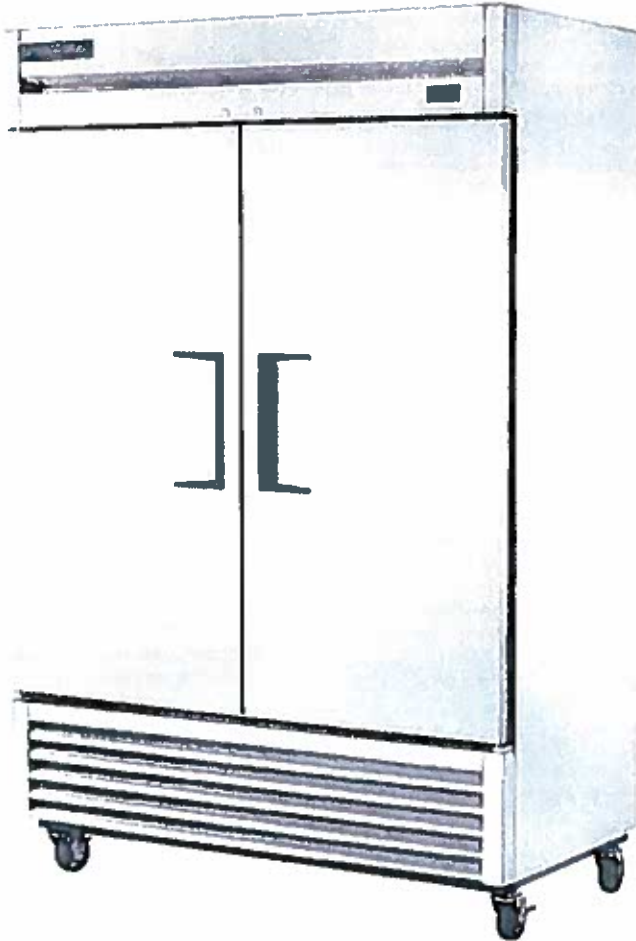

T-49F-HC

- ▶ True's solid door reach-in's are designed with enduring quality that protects your long term investment.
- ▶ Designed using the highest quality materials and components to provide the user with colder product temperatures, lower utility costs, exceptional food safety and the best value in today's food service marketplace.
- ▶ Factory engineered, self-contained capillary tube system using environmentally friendly R290 hydrocarbon refrigerant that has zero (0) ozone depletion potential (ODP), & three (3) global warming potential (GWP).
- ▶ High capacity, factory balanced refrigeration system that maintains -10°F (-23.3°C) temperatures. Ideal for both frozen foods and ice cream.
- ▶ Stainless steel solid doors and front. The very finest stainless with higher tensile strength for fewer dents and scratches.
- ▶ Adjustable, heavy duty PVC coated shelves
- ▶ Positive seal self-closing doors. Lifetime guaranteed door hinges and torsion type closure system.
- ▶ Automatic defrost system time-initiated, temperature-terminated. Saves energy consumption and provides shortest possible defrost cycle.

Bottom mounted units feature:

- ▶ "No stoop" lower shelf.
- ▶ Storage on top of cabinet
- ▶ Compressor performs in coolest, most grease free area of kitchen
- ▶ Easily accessible condenser coil for cleaning

ROUGH-IN DATA

Chart dimensions rounded up to the nearest 1/8" Specifications subject to change without notice (millimeters rounded up to next whole number)

Model	Doors	Shelves	Cabinet Dimensions (inches) (mm)			HP	Voltage	Amps	NEMA Config.	Cord Length (total ft.) (total m)	Crated Weight (lbs.) (kg)
			W	D	H*						
T-49F-HC	2	6	54 1/8	29 1/2	78 3/8	1	115/60/1	9.6	5-15P	9	440
			1375	750	1991	1	230-240/50/1	5.5	▲	2.74	200

* Height does not include 5" (127 mm) for castors or 6" (153 mm) for optional legs.

▲ Plug type varies by country

    	APPROVALS: _____	AVAILABLE AT: _____
6/17 Printed in U.S.A.		

Model:
T-49F-HC

T-Series:
Reach-In Solid Swing Door Freezer with Hydrocarbon Refrigerant



STANDARD FEATURES

DESIGN

- True's commitment to using the highest quality materials and oversized refrigeration systems provides the user with colder product temperatures, lower utility costs, exceptional food safety and the best value in today's food service marketplace.

REFRIGERATION SYSTEM

- Factory engineered, self-contained, capillary tube system using environmentally friendly R290 hydro carbon refrigerant that has zero (0) ozone depletion potential (ODP), & three (3) global warming potential (GWP).
- High capacity, factory balanced refrigeration system that maintains -10°F (-23.3°C) temperatures. Ideal for both frozen foods and ice cream.
- State of the art, electronically commutated evaporator and condenser fan motors. ECM motors operate at higher peak efficiencies and move a more consistent volume of air which produces less heat, reduces energy consumption and provides greater motor reliability.
- Bottom mounted condensing unit positioned for easy cleaning. Compressor runs in coolest and most grease free area of the kitchen. Allows for storage area on top of unit.
- Automatic defrost system time-initiated, temperature-terminated. Saves energy consumption and provides shortest possible defrost cycle.

CABINET CONSTRUCTION

- Exterior - Stainless steel front. Anodized quality aluminum ends. Corrosion resistant GalFan coated steel back.

- Interior - attractive, NSF approved, clear coated aluminum liner. Stainless steel floor with coved corners.
- Insulation - entire cabinet structure and solid door are foamed-in-place using a high density, polyurethane insulation that has zero ozone depletion potential (ODP) and zero global warming potential (GWP).
- Welded, heavy duty steel frame rail, black powder coated for corrosion protection.
- Frame rail fitted with 4" (102 mm) diameter stem castors - locks provided on front set.

DOORS

- Stainless steel exterior with clear aluminum liner to match cabinet interior. Doors extend full width of cabinet shelf. Door locks standard.
- Lifetime guaranteed recessed door handles. Each door fitted with 12" (305 mm) long recessed handle that is foamed-in-place with a sheet metal interlock to ensure permanent attachment.
- Positive seal self-closing doors. Lifetime guaranteed door hinges and torsion type closure system.
- Magnetic door gaskets of one piece construction, removable without tools for ease of cleaning.

SHELVING

- Six (6) adjustable, heavy duty PVC coated wire shelves 24 1/8" L x 22 1/2" D (624 mm x 569 mm). Four (4) chrome plated shelf clips included per shelf.
- Shelf support pilasters made of same material as cabinet interior; shelves are adjustable on 1/2" (13 mm) increments.

LIGHTING

- LED Interior lighting - safety shielded. Lights activated by rocker switch mounted above doors.

MODEL FEATURES

- Exterior temperature display.
- Evaporator is epoxy coated to eliminate the potential of corrosion.
- Rear airflow guards prevent product from blocking optimal airflow.
- NSF/ANSI Standard 7 compliant for open food product.

ELECTRICAL

- Unit completely pre-wired at factory and ready for final connection to a 115/60/1 phase, 15 amp dedicated outlet. Cord and plug set included.



115/60/1
NEMA-5-15R

OPTIONAL FEATURES/ACCESSORIES

Upcharge and lead times may apply.

- ┆ 230 - 240V / 50 Hz.
- ┆ 6" (153 mm) standard legs.
- ┆ 6" (153 mm) seismic/flanged legs.
- ┆ Alternate door hinging (factory installed).
- ┆ Novelty baskets.
- ┆ Additional shelves.
- ┆ Half door bun tray racks. Each holds up to eleven 18" L x 26" D (458 mm x 661 mm) sheet pans (sold separately) (airflow guards need to be removed).
- ┆ Full door bun tray racks. Each holds up to twenty-two 18" L x 26" D (458 mm x 661 mm) sheet pans (sold separately) (airflow guards need to be removed).

PLAN VIEW

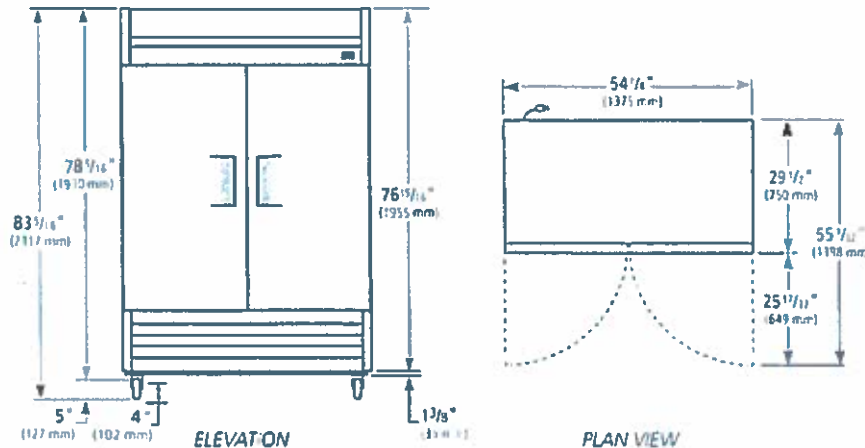

WARRANTY*
Three year warranty on all parts and labor and an additional 2 year warranty on compressor. (U.S.A. only)

METRIC DIMENSIONS ROUNDED UP TO THE NEAREST WHOLE MILLIMETER

SPECIFICATIONS SUBJECT TO CHANGE WITHOUT NOTICE

	Model	Elevation	Right	Plan	3D	Back
	T-49F-HC					

*RESIDENTIAL APPLICATIONS: True assumes no liability for damage or loss coverage for component failures, factory defect or any other damages for units installed in non-commercial foodservice or residential applications.

TRUE FOOD SERVICE EQUIPMENT

2001 East Terra Lane • O'Fallon, Missouri 63366-4434 • (636)240-2400 • Fax (636)272-2408 • Toll Free (800)325-6152 • Intl. Fax# (001)636-272-7546 • www.truefmfg.com



We put space to work

Item # _____

Job _____

Metro C5 1 Series Non-Insulated Heated Holding and Proofing Cabinets

- **Control:** Three holding modules are available. All feature an easy-to-read digital thermometer, recessed control dials, a master on/off switch, and power indicator lights.
 - **Combination Module:** At the flip of a switch change from heated holding mode to proofing mode. Individual analog controls for temperature and humidity levels. Digital temperature display.
 - **Holding Module:** For heated holding applications. Analog temperature control with digital display.
 - **Proofing Module:** For proofing applications only. Individual analog controls for temperature and humidity levels. Digital temperature display.
- **Performance:** All modules provide fast heat up and recovery through a thermostatically controlled, forced air heating system.
- **Sizes:** C5 1 Series cabinets are available in Full Height (69 1/2", 1772mm), 3/4 Height (57 3/4", 1467mm), and 1/2 Height (42 1/2", 1096mm) sizes.
- **Doors:** Clear polycarbonate doors provide visibility of the contents of the cabinet without the heat loss associated with opening the door.
- **Capacity:** Three slide styles provide maximum holding capacity.
 - **Universal:** Adjustable wire slides, with SiteSelect™, hold 18"x26" sheet, 12"x20" steam table, 2/1 or 1/1 GN pans, and adjust on 1 1/2" (38mm) increments.
 - **Lip Load:** Fixed aluminum extrusions hold 18"x26" sheet pans on 1 1/2" (38mm) increments.
 - **Fixed Wire:** Fixed slides hold 18"x26" sheet, 12"x20" steam table, 2/1 GN, or 1/1 GN pans on 3" (76mm) increments.
- **Removable Module:** All modules are removable, without tools, for easy cleaning of the cabinet interior. Future module upgrades or changes can occur without cabinet body replacement.
- **Reliability:** Reliability and durability are designed into every C5. High quality components provide a long life of worry-free use.



Full Height
Fixed Slides
Combination
Module



1/2 Height
Fixed Slides
Combination
Module



3/4 Height
Fixed Slides
Combination
Module



1 Series Removable Control Modules

- **Holding Module:** Hot holding at higher temperatures without moisture control.
- **Proofing Module:** Proofing at lower temperatures. Heat and moisture control for proofing applications.
- **Combination Module:** Hot holding and proofing. Moisture control at lower temperatures (proofing).

All Metro Catalog Sheets are available on our website www.metro.com



InterMetro Industries Corporation
North Washington Street, Wilkes-Barre, PA 18705
Product Information: U.S. and Canada: 1-800-992-1776
Outside U.S. and Canada: www.metro.com/contact-us

103-267
Printed in U.S.A. Rev. 5/18

Information and specifications are subject to change without notice. Please confirm at time of order.

Copyright © 2018 InterMetro Industries Corp.



C5 1 Series Non-Insulated Heated Holding and Proofing Cabinets

13.91



We put space to work

13.91

C5 1 Series Non-Insulated Heated Holding and Proofing Cabinets

Job _____

C5 1 Series Non-Insulated Heated Holding and Proofing Cabinets

Specifications

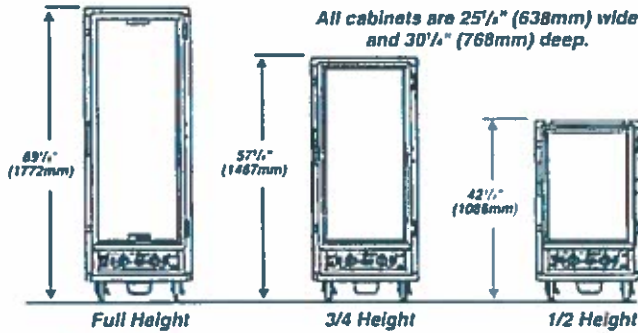

- Cabinet Material:** .063" (1.8mm) aluminum natural interior or brushed exterior with .125" (3.2mm) aluminum chassis.
- Casters:** Four casters with 5" (127mm) donut neoprene wheel double ball bearing swivel, ball bearing axle, nickel plated two with brake.
- Clear Doors:** Extruded aluminum powder coated frame with .090" (2.3mm) polycarbonate window.
- Hinges:** Field reversible double hinged 180° swing with long-life nylon bearings.
- Gaskets:** High temperature door mounted Santoprene gaskets
- Latches:** Polymer high-strength, magnetic pull latch with lever-action release.
- Universal Slides:** 1/2" (6.4mm) dia. nickel-chrome electroplated wire adjustable on 1/2" (38mm) increments
- Lip Load Slides:** 1 1/2" x 1/2" x .063" (38x38x1.8mm) extruded aluminum channel slides 1 1/2" (38mm) fixed spacing.
- Fixed Wire Slides:** 1/2" (6.4mm) dia. nickel-chrome electroplated wire welded on 3" (76mm) spacing
- Drip Trough:** Smooth polymer drip trough with catch pan
- Holding Modules:** Removable without tools, digital thermometer recessed control dials, master on/off switch, "Power On" light, water pan, ball bearing blower forced air system, 7' cord UL CUL and NSF Listed

Electrical and Performance:

- Combination Module:** 80°F (27°C) to 190°F (89°C) operating temperature range, 95% RH at 95°F (35°C). Available in 120V 2000W & 1440W, and 220-240V 1681-2000W configurations
- Holding Module:** 80°F (27°C) to 190°F (89°C) operating temperature range. Available in 120V 2000W & 1440W, and 220-240V 1681-2000W configurations
- Proofing Module:** 80°F (27°C) to 120°F (49°C) operating temperature range, 95% RH at 95°F (35°C). Available in 120V 1440W and 220-240V 1210-1440W configurations.

Slide Capacities:

Cabinet Size	Universal Wire Pan Capacity**				Lip Load Pan Capacity		Fixed Wire Pan Capacity	
	Slide Pairs Provided	Max. *	18" x 26"	12" x 20" x 2.5" GN 1/1	18" x 26"	18" x 26"	12" x 20" x 2.5" GN 1/1	
Full Height	18	37	18	34	35	18	34	
3/4 Height	14	29	14	26	27	14	26	
1/2 Height	8	17	8	16	17	8	16	

*Maximum number of slide pairs @ 1" spacing. Additional slide pairs ordered separately
**Capacity based on standard number of slides provided

Cabinet Height
9 = Full Height
7 = 3/4 Height
5 = 1/2 Height

Module Type
C = Combination
H = Heated Holding
P = Proofing

Slide Type
U = Universal Wire
4 = Fixed Wire
L = Lip Load Aluminum

C519-CFC-U



For Combination and Holding Module Cabinets (120V 16A 60Hz 2000W)

Door Style
FC = Full Length Clear



For Proofing Module Cabinets (120V 12A 60Hz 1440W)

Export Model Number Description

C519-CXFC-U



Add "X" for Export Cabinets
For Combination and Holding Modules (220-240V 76-83A 50/60Hz 1681-2000W)
For Proofing Modules (220-240V 5.5-6A 50/60Hz 1210-1440W)

Models with Accessories or Options

C519-CFC-UA

An "A" suffix indicates that accessories need to be factory assembled to the cabinet. Order accessories separately.

Options/Accessories

- Small Item Shelf (C5-SHELF-S)
- Stainless Steel Legs (C5-SSLEGS)
- Universal Slide Pair, Chrome (C5-USLIDEPR-C)
- 6" Casters (C5-6CASTER)
- Rear Rig'd Casters (C5-5RDGCSTR)
- Travel Latch (C5-TRVL)
- Flush Door Latch (C5-LATCHFLUSH-1)
- Rear Push Handle (C5-RHANDLE)
- Perimeter Bumper (C5-PERMBUMP-1)
- Straight Plug, 20 Amp, 120V (C5-STRPLG-20)
- Straight Plug, 15 Amp, 120V (C5-STRPLG-15)
- Factory Left-Hand Hinging (DD3768)
- Stainless Steel Universal Slides (please call)

Metro Heated cabinets are for hot food holding applications only.

McQuay-Newton



The Spirit of Excellence





iT0500 Ice Cube Machine

iT0500 Ice Cube Machine

Models

- IRT0500A
- IDT0500A
- IYT0500A
- IRT0500W
- IDT0500W
- IYT0500W

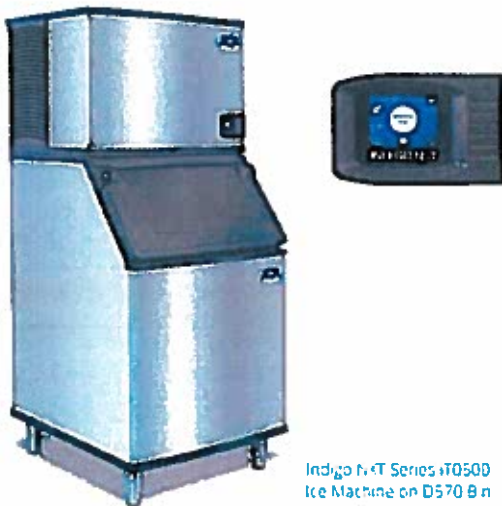

Indigo NXT Series iT0500 Ice Machine on D570 B n

Designed for operators who know that ice is critical to their business, the Indigo NXT Series ice machine's preventative diagnostics continually monitor itself for reliable ice production. Improvements in cleanability and programmability make your ice machine easy to own and less expensive to operate

- **New Levels of Performance** - Showcasing an average of 12% lower energy consumption and a 23% reduction in condenser water usage. This translates into lower cost of ownership over the life of your machine.
- **easyTouch® Display** - New icon based touch screen takes the guess work out of owning and operating an ice machine.
- **Programmable Ice Production** - Now its super easy to program your ice machine to be off at certain times of the day to save money with fluctuating electrical rates. Also programmable by daily ice production volume.
- **Easy to Clean Foodzone** - Hinge front door swing out for easy access. Removable water trough, distribution tube, curtain, water probe and water pump for fast and efficient cleaning. Selected components are made with AlphaSan® antimicrobial.
- **Intelligent Diagnostics** - Provides 24 hour preventative maintenance and diagnostic feedback for trouble free operation.
- **Acoustical Ice Sensing Probe** - Unique patented technology allows for reliable operation in challenging water conditions and environments.
- **DuraTech® Exterior** - Provides superior corrosion resistant above stainless steel. Innovative clear-coat resists fingerprints and dirt making it easier to keep clean.
- **Available Lumince® II Growth Inhibitor** - Controls the growth of bacteria and yeast within the Food zone keeping the machine cleaner longer. A new indicator in the display keeps you abreast of the operational status.

Ice Machine Electric

115/60/1 standard
(208-230/60/1 also available)

Minimum circuit ampacity:

Air-cooled 115v 11.5, 208-230v 5.1
Water-cooled 115v 10.8

Maximum fuse size:

Air Cooled 15 amps
Water cooled 15 amps



Specifications

BTU Per Hour:

3,800 (average),
and 6,000 (peak)

Refrigerant:

R410A CFS - Free
Lowers global warming
by 48%

Operating Limits:

- Ambient Temperature Range 40° to 110° F (4.4° to 43.3° C)
- Water Temperature Range 40° to 90° F (4.4° to 32.2° C)
- Water Pressure Ice Maker Water In
Min. 20 psi (137.9 kPa)
Max. 80 psi (551.1 kPa)

Ice Shape

Half Dice
3/4" x 1 1/4" x 3/4"
(9.5 x 2.86 x 2.22 cm)



Dice
7/8" x 7/8" x 3/8"
(2.22 x 2.22 x 2.22 cm)



Regular
1 1/4" x 1 1/4" x 3/4"
(2.86 x 2.86 x 2.22 cm)



COMPANY WITH QUALITY SYSTEM

2110 South 26th Street
Manitowoc, WI 54220

Tel: 1.920.682.0161
Fax: 1.920.683.7589

www.manitowocice.com





Indigo® NXT™ iT0500 Ice Cube Machine

iT0500 on D-570 Storage Bin

- ① Minimum Clearance (2 Options)
- ② 1/8" (3.18 cm) FFP Water Condensate Inlet (water-cooled units)
- ③ 1/2" (1.27 cm) FFP Water Condensate Outlet (water-cooled units)
- ④ 1/2" (1.27 cm) Auxiliary Base Drain Socket
- ⑤ 1/8" (3.18 cm) FFP Ice Making Water Inlet
- ⑥ 1/2" (1.27 cm) FFP Ice Making Water Drain
- ⑦ 1/4" (6.35 cm) Bin Drain

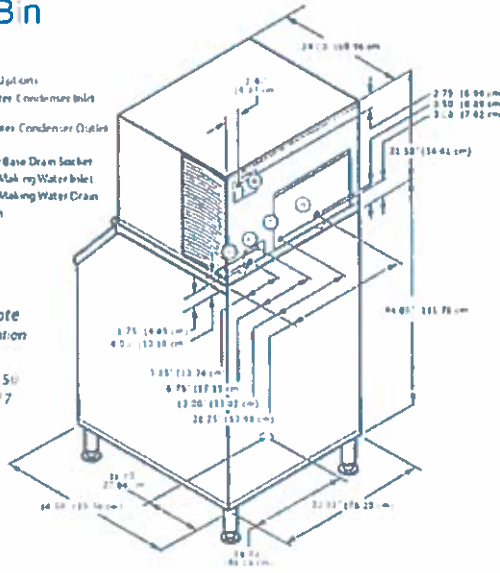

Installation Note
Minimum installation clearance
Top/side 12" (30.5 cm)
Back 5" (12.7 cm)

Space-Saving Design

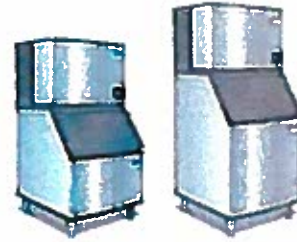

	iT0500 D-400	iT0500 D-570
Height	59.50" / 151.13 cm	71.50" / 181.61 cm
Width	30.00" / 76.2 cm	30.00" / 76.2 cm
Depth	34.00" / 86.30 cm	34.00" / 86.30 cm
Bin Storage	365 lbs / 165.7 kgs	543 lbs / 241.1 kgs

Height includes adjustable bin legs 6.00" to 8.00" (15.24 to 20.32 cm) set at 6.00" (15.24 cm)
Bin capacity is based on 90% of the volume x 33 lbs/ft³ average density of ice

Specifications

	Model	Ice Shape	Ice Production 24 Hours		Power Usage kWh/100 lbs. @90°F Air/70°F	Potable Water Usage/100 lbs. 45.4 kgs. of Ice
			70°F Air/ 50°F Water	90°F Air/ 70°F Water		
AIR COOLED	IRT0500A	Regular	500 lbs / 227 kgs	386 lbs / 175 kgs	5.04 ★	19 Gal / 71.9 L
	IDT0500A	dice	520 lbs / 236 kgs	400 lbs / 181 kgs	5.25 ★	19 Gal / 71.9 L
	IYT0500A	half-dice	550 lbs / 249 kgs	440 lbs / 200 kgs	4.58 ★	19 Gal / 71.9 L
WATER COOLED	IRT0500W	Regular	500 lbs / 227 kgs	406 lbs / 184 kgs	4.30	19 Gal / 71.9 L
	IDT0500W	dice	500 lbs / 227 kgs	400 lbs / 181 kgs	4.41	19 Gal / 71.9 L
	IYT0500W	half-dice	535 lbs / 243 kgs	460 lbs / 209 kgs	3.90	19 Gal / 71.9 L

* Water-cooled Condenser Water Usage / 100 lbs. / 45.4 kgs. Of Ice: 130 gal/ 492 L.
*Water-cooled models are excluded from ENERGY STAR qualification.

Accessories

Lumince® II Growth Inhibitor
reduces yeast and bacteria growth for a cleaner ice machine

External Scoop holder
Protect the ice scoop with the NSF approved versatile scoop holder

Arctic Pure® Water Filters
Reduces sediment and chlorine odors for better tasting ice.

iAUCS®
schedules and performs routine ice machine cleaning automatically

WELBILT reserves the right to make changes to the design or specifications without prior notice

2110 South 26th Street
Manitowoc, WI 54220

Tel: 1.920.682.0161
Fax: 1.920.683.7589

www.manitowocice.com
64798 06/19





ICE MACHINE WARRANTY

Manitowoc Ice, Inc. (hereinafter referred to as the "COMPANY") warrants for a period of thirty-six months from the installation date (except as limited below) that new ice machines manufactured by the COMPANY shall be free of defects in material or workmanship under normal and proper use and maintenance as specified by the COMPANY and upon proper installation and start-up in accordance with the instruction manual supplied with the ice machine. The COMPANY'S warranty hereunder with respect to the compressor shall apply for an additional twenty-four months, excluding all labor charges, and with respect to the evaporator for an additional twenty-four months, including labor charges.

The obligation of the COMPANY under this warranty is limited to the repair or replacement of parts, components, or assemblies that in the opinion of the COMPANY are defective. This warranty is further limited to the cost of parts, components or assemblies and standard straight time labor charges at the servicing location.

Time and hourly rate schedules, as published from time to time by the COMPANY, apply to all service procedures. Additional expenses including without limitation, travel time, overtime premium, material cost, accessing or removal of the ice machine, or shipping are the responsibility of the owner, along with all maintenance, adjustments, cleaning, and ice purchases. Labor covered under this warranty must be performed by a COMPANY Contracted Service Representative or a refrigeration service agency as qualified and authorized by the COMPANY'S local Distributor. The COMPANY'S liability under this warranty shall in no event be greater than the actual purchase price paid by customer for the ice machine.

The foregoing warranty shall not apply to (1) any part or assembly that has been altered, modified, or changed, (2) any part or assembly that has been subjected to misuse, abuse, neglect, or accidents, (3) any ice machine that has been installed and/or maintained inconsistent with the technical instructions provided by the COMPANY, or (4) any ice machine initially installed more than five years from the serial number production date. This warranty shall not apply if the Ice Machine's refrigeration system is modified with a condenser, heat reclaim device, or parts and assemblies other than those manufactured by the COMPANY, unless the COMPANY approves these modifications for specific locations in writing.

THIS WARRANTY IS IN LIEU OF ALL OTHER WARRANTIES OR GUARANTEES OF ANY KIND, EXPRESSED OR IMPLIED, INCLUDING ANY IMPLIED WARRANTY OF MERCHANTABILITY OR FITNESS FOR A PARTICULAR PURPOSE.

In no event shall the COMPANY be liable for any special, indirect, incidental or consequential damages. Upon the expiration of the warranty period, the COMPANY'S liability under this warranty shall terminate.

The foregoing warranty shall constitute the sole liability of the COMPANY and the exclusive remedy of the customer or user. To secure prompt and continuing warranty service, the warranty registration card or register on file within five (5) days from the installation date.

MANITOWOC ICE, INC.

2110 So. 26th St., P.O. Box 1720, Manitowoc, WI 54221-1720
Telephone: 920-682-0161 • Fax: 920-683-7585
Web Site - www.manitowocice.com
Form 80-0373-3 Rev. 01/02



Ice Storage Bins

Ice Storage Bins

Model

- D320
 D400
 D420
 D570
 D970

D Bins

*(1.94 cm) Bin depth

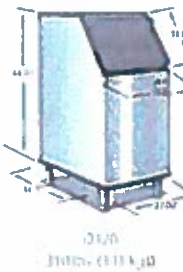
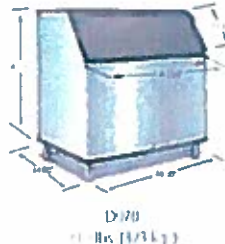
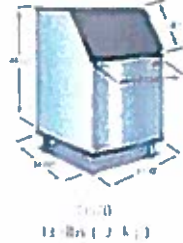

Ergonomic NSF approved sanitary scoop included

D Bin Features

New Sanitary Scoop Ergonomic NSF approved sanitary ice scoop included with each bin. Built-in knuckle and thumb guard. Unique molded retaining lip allows maximum scooping every time. Per scoop capacity approximately 5.3/ lbs (2.4 kg)

Scoop Holder options New built-in scoop holder, keeps the ice scoop handle above the ice, or purchases the optional NSF approved External Scoop Holder Kit # K00461.

New Door design Clever built-in side grips allow you to lift the bin door from anywhere you are standing (left, right or center) even when you have just one hand free

Foamed Insulated Door Insulates the ice bin, reduces sweat on the door, helps keep ice lasting longer.

Stay up door Unique cammed bin door self-latch keeps the door in the open position and keeps the employee safe when scooping ice

Ergonomic Door design Door is angled 53 degrees to allow for easier access to the ice in the bin especially when scooping from the bottom.

Duratech Metal Finish Manitowoc exterior material has better corrosion resistance than stainless steel, is smudge resistant and easy to keep clean.

New Bin Liner Polyurethane Artic Blue bin liner accentuates the crisp clear ice from a Manitowoc Ice Machine

Warranty

Bin & Accessories 3 Year Parts & Labor.

D Bin Model	D-Bin Capacities				D-Bin Dimensions					
	*Application Capacity		**2018 AHRI Capacity		Height		Width		Depth	
	lbs.	kgs	Cu. ft	Cu. M	in.	cm	in.	cm	in.	cm
D320	264	119.90	8.9	0.25	38	96.5	22	55.9	34	86.4
D420	381	173.79	12.9	0.37	50	127	22	55.9	34	86.4
D400	365	165.70	12.3	0.35	38	96.5	30	76.2	34	86.4
D570	532	241.14	17.9	0.51	50	127	30	76.2	34	86.4
D970	882	400.11	29.7	0.84	50	127	48	121.9	34	86.4

*Application Capacity based on 90% of the volume x 33 lbs/ft³ average density of ice. Ice must be managed.
 **2018 AHRI certified measurement for bin capacity
 Above bin heights include leg height of 6" / 15.24 cm
 All bins include sanitary plastic scoop and one set of adjustable (1) to 7.75 in / 19.71 to 20.32 cm chrome legs
 External Scoop holder order separately Kit # K00461
 Metal Scoop order separately Kit # K00461



Welbilt reserves the right to make changes to the design or specifications without prior notice

2110 South 26th Street
Manitowoc, WI 54220

Tel: 1.920.682.0161
Fax: 1.920.683.7589

www.manitowocice.com
6453C
01/20





D Bins

Indigo Ice Machines Series											
Machine		iT420	iT620	iF0300, iT0300	iT450	iT0500 &iF0500N	iF0600N, iF0600C, iT0750	iF0900N, iT0900, iF0900C	iT1200, iT1200C	iF1400C, iF1800C	iT1500, iT1900
Machine Capacity @90/70 F		375	465	240	378	440	555, 530	710, 714	950, 1000	1200 1470 1600	1360, 1455
Bins	Bin Cap	Width	22"	22"	30"	30"	30"	30"	30"	30"	48"
D320	264	22"	*	*							
D420	383	22"	*	*							
D400	365	30"	K00472	K00472	*	*	*	NR	NR	NR	
D570	532	30"	K00472	K00472	*	*	*	*	*	NR	
D970	882	48"	NR	NR	NR	K00470	K00470	K00470	K00470	K00471 + K00470	*

Manitowoc Flaker and Nugget Machines											
Machine		RNF320	RFF320	RNF620	RFF620	RNF1020	RFF1220C	RNF1100	RFF1300 & RNF2000C	RFF2200C	
Machine cap		251	286	451	540	825	958	825	874	1702	
Bins	Bin cap	Width	22"	22"	22"	22"	22"	30"	30"	36.7"	
D320	264	22"	*	*	NR	NR	NR				
D420	383	22"	*	*	*	NR	NR				
D400	365	30"	K00472	K00472	K00472	K00472	NR	NR	NR		
D570	532	30"	NR	K00472	K00472	K00472	NR	NR	*	*	
D970	882	48"	NR	NR	K00473	K00473	K00473 if 2 used.	K00473 if 2 used.	K00470	K00470	K00470

An optional adapter is required when putting a narrower ice machine on a wider bin.
 * No adapter is needed.
 NR = Not Recommended. Bin too small or too large for application.
 Putting a wider machine on narrower bins is not an option.
 Machines side by side may be water cooled or remote.
 Application Bin Capacity shown in lbs using the AHRI rating based on 70% of total volume x 33 lbs./ft³ average density of ice.
 Machine capacity shown in lbs./24hrs using the AHRI rating base at 90F ambient, 70F water temperature.

Ice Storage Bins

Available Accessories See price book for replacement scoops, legs, specialty legs and casters

K00146 Convenient Ice Bagger

Includes bagger, D-bin adapter, and 250 bags and ties (Not for D320 or D400) Order K00068 replacement bags



K00461 External Scoop Holder

NSF approved. Can be mounted on the left or right side of bins, horizontally or vertically or on a wall.



K00463 Metal Scoop

Indestructible NSF approved aluminum alloy with sanitary knuckle and thumb guard. Works with K00461 external scoop holder or hangs inside the D-Bin series. Limited life time guarantee.



K00462 Secure Fastening Kit

Securely fast the Indigo® ice machine head to the pre-drilled inserts on the back of the D-bin series. Stainless steel flanged feet attach to bin and can be screwed to the floor.

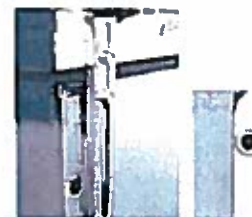

Welbilt reserves the right to make changes to the design or specifications without prior notice.

2110 South 26th Street
Manitowoc, WI 54220

Tel: 1.920.682.0161
Fax: 1.920.683.7589

www.manitowocice.com
6453C
01/20





LIMITED WARRANTY FOR ICE STORAGE BIN & DISPENSERS

LIMITED WARRANTY

Manitowoc Ice a division of Manitowoc FSG Operations, LLC, ("Company") warrants that new Ice Storage Bins or Dispensers sold by Company shall be free of defects in material or workmanship under normal and proper use and maintenance as specified by the Company and upon proper installation and start-up in accordance with the instruction manual supplied

WHAT IS COVERED

- Parts and Labor for a period of three (3) years.
 - Accessory Ice Transport Carts for two (2) years parts and labor
- The Ice Storage Bin / Dispenser warranty begins on the date of the original installation. This warranty shall not apply to any Ice Storage Bin or Dispenser initially installed more than five (5) years from the serial number production date.

The obligation of the Company under this warranty is limited to the repair or replacement of parts, components, or assemblies that in the sole opinion of the Company are defective. This warranty is further limited to the cost of parts, components or assemblies and standard straight time labor charges at the servicing location.

Time and hourly rate schedules, as published from time to time by the Company, apply to all service procedures. Additional expenses including without limitation, travel time, overtime premium, material cost, accessing or removal of the Ice Storage Bin / Dispenser, or shipping are the responsibility of the purchaser, along with all maintenance, adjustments, cleaning, and ice purchases. Labor covered under this warranty must be performed by an approved Company contracted Service Representative or a refrigeration service agency as qualified and authorized by the Company's local Distributor. The Company's liability under this warranty shall in no event be greater than the actual purchase price paid by purchaser for the Ice Storage Bin or Dispenser.

EXCLUSIONS FROM COVERAGE

- Repair or replacement of parts required because of misuse, improper care or storage, negligence, alteration, use of incompatible supplies or lack of specified maintenance shall be excluded.
- Normal maintenance items
Failures caused by adverse environmental, water conditions, or improper drainage
- Improper or unauthorized repair
- Any Ice Storage Bin / Dispenser that has been installed and/or maintained inconsistent with the instructions provided by the Company.
- Parts subject to damage beyond the control of Company, or to Ice Storage Bin's / Dispenser's which have been subject to accidents, damage in shipment, fire, floods, other hazards or acts of God that are beyond the control of the Company.
- This Limited Warranty shall not apply if the Ice Storage Bin / Dispenser is modified with parts and assemblies other than those manufactured by the Company, unless the Company approves these modifications for specific locations in writing prior to the commencement of such modification.

LIMITATIONS OF LIABILITY

The preceding paragraphs set forth the exclusive remedy for all claims based on failure of, or defect in, Ice Storage Bins or Dispensers sold hereunder, whether the failure or defect arises before or during the warranty period, and whether a claim, however instituted, is based on contract, indemnity, warranty, tort (including negligence), strict liability, implied by statute, common-law or otherwise, and Company and agents shall not be liable for any claims for personal injuries or consequential damages or loss, howsoever caused. Upon the expiration of the warranty period, all such liability shall terminate. **THE FOREGOING WARRANTIES ARE EXCLUSIVE AND IN LIEU OF ALL OTHER WARRANTIES, WHETHER WRITTEN, ORAL, IMPLIED OR STATUTORY. NO IMPLIED WARRANTY OF MERCHANTABILITY OR FITNESS FOR PARTICULAR PURPOSE SHALL APPLY. COMPANY DOES NOT WARRANT ANY PRODUCTS OR SERVICES OF OTHERS.**

REMEDIES

The liability of Company for breach of any warranty obligation hereunder is limited to: (i) the repair or replacement of the Ice Storage Bin or Dispenser on which the liability is based, or with respect to services, re-performance of the services, or (ii) at Company's option, the refund of the amount paid for said equipment or services. Any breach by Company with respect to any item or unit of equipment or services shall be deemed a breach with respect to that item or unit or service only.

WARRANTY CLAIM PROCEDURE

Customer shall be responsible to:

- Complete and return warranty registration card or register on line within five (5) days from the installation date.
- All warranty service must be performed by an approved Manitowoc contracted or authorized Service Representative. To schedule a service appointment contact your local Manitowoc Service Representative or visit us at www.manitowocice.com to find a Service Representative near you.

GOVERNING LAW

This Limited Warranty shall be governed by the laws of the state of Wisconsin, USA, excluding their conflicts of law principles. The United Nations Convention on Contracts for the International Sale of Goods is hereby excluded in its entirety from application to this Limited Warranty.

COMPLETE AND RETAIN FOR YOUR RECORD:

Distributor/Dealer _____

Model Number _____

Serial Number _____

Installation Date _____

Manitowoc Ice
2110 South 26th Street
P.O. Box 1720
Manitowoc, WI 54221-1720
Web site: www.manitowocice.com

Rev 2 1/2/2012



Item: _____

Quantity: _____

Project: _____

50 lb. Deep Fat Fryer

50 lb. Deep Fat Fryer

Models: RFT-50 RFT-DS



RFT-50

Gas Type: Natural LP

Elevation (if above 2000 ft.): _____

Options and Accessories

- Stainless steel tank cover
- Stainless steel side splash guard
- Stainless steel joiner strip
- 48" quick disconnect and restraining cable
- 5" swivel casters (set of four - 2 locking)

Standard Features

- All stainless steel front and sides
- 50 lb capacity stainless steel tank assembly
- 14" x 14" frying area
- Cast iron burners rated at 38,000 BTU/hr each
- Millivolt control system with 100% safety shut off
- Thermostatic control with 200°-400° F range
- Two fry baskets with plastic coated handles for ease of handling
- 1½" full port drain valve
- 6" high adjustable heavy duty legs
- Five year limited (prorated) warranty on S/S tank
- DS - Dump Station
- One year limited warranty, parts and labor



50 lb. Deep Fat Fryer

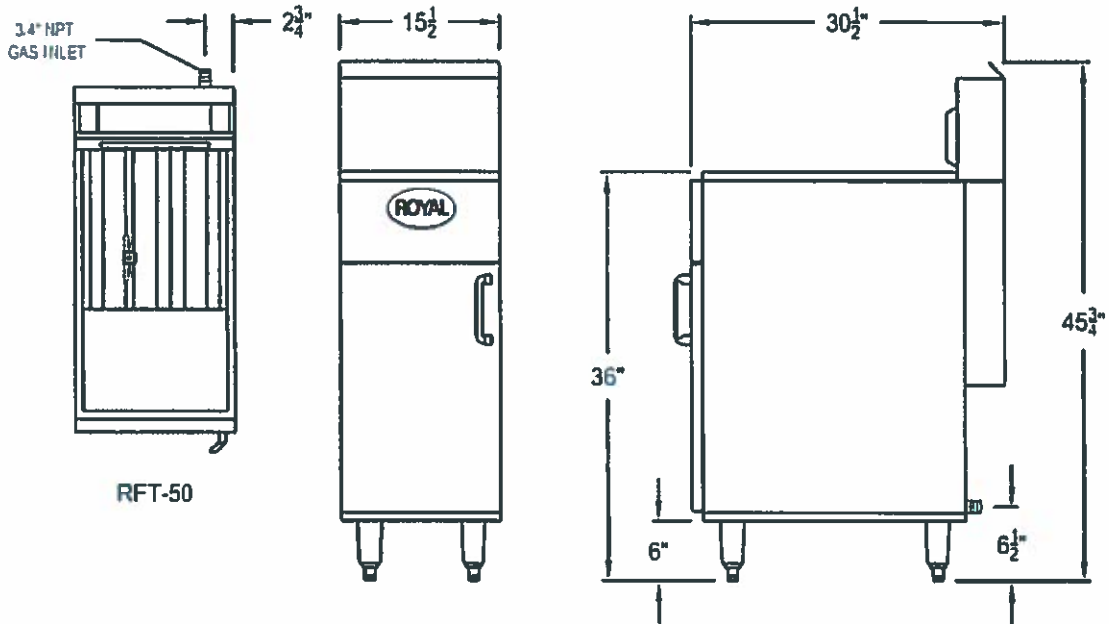

Model Number	Cooking Area	Number of Burners	Total BTU	Ship Weight
RFT-50	14" x 14"	3	114,000	210 lbs.
RFT-DS				130 lbs.

Notes:

- Burner rated at 38,000 BTU/hr each

Gas Connection:

3/4" NPT on the left hand rear of the appliance.
No external pressure regulator required.

Gas Pressure:

4" W.C.	Natural Gas
11" W.C.	Propane

Clearances:

	Combustible	Non-Combustible
Rear	6"	0"
Sides	6"	0"

Specify type of gas and altitude, if over 2,000 feet, when ordering.

Due to continuing product development to ensure best possible performance, these specifications are subject to change without prior notification.

Royal Range of California, Inc.

3245 Corridor Dr. • Eastvale, CA 91752 • (800) 769-2414 • (951) 360-1600
Fax: (951) 360-7500 • www.royalranges.com • sales@royalranges.com

11/19



Item: _____

Quantity: _____

Project: _____

Manual Griddle

Manual Griddle

Models:	<input type="checkbox"/> RMG-12	<input type="checkbox"/> RMG-18	<input type="checkbox"/> RMG-24	<input type="checkbox"/> RMG-36
	<input type="checkbox"/> RMG-48	<input type="checkbox"/> RMG-60	<input type="checkbox"/> RMG-72	



RMG-36

Gas Type: Natural LP

Elevation (if above 2000 ft.): _____

Standard Features

- 11" high, Low Profile
- Large 1½ gallon capacity stainless steel grease can
- Compact heavy gauge chassis for long life
- Stainless steel sides, front valve cover and ledge
- Double wall panels for cooler sides
- Aeration panels between the burners for added efficiency
- Stainless Steel "U" shaped burner every 12" rated at 30,000 BTU/hr
- 3/4" thick griddle plate with polished cooking surface
- Manual control for each burner
- 4" wide S/S grease trough with large drain opening for easy cleaning
- Stainless steel tubing for pilots
- 4" high adjustable heavy duty legs included

Options and Accessories

- 1" thick griddle plate
- Grooved griddle (specify width: _____")
- Chrome griddle plate
- Stainless Steel Equipment Stand
 - Knock Down All Welded
- Size
 - 12" 18" 24" 30" 36" 48" 60" 72"
 - 5" swivel casters (set of four - 2 locking)
 - 5" swivel casters (set of six - 3 locking) (60" and 72" models)



2 YEAR LIMITED, PARTS AND LABOR WARRANTY

Manual Griddle

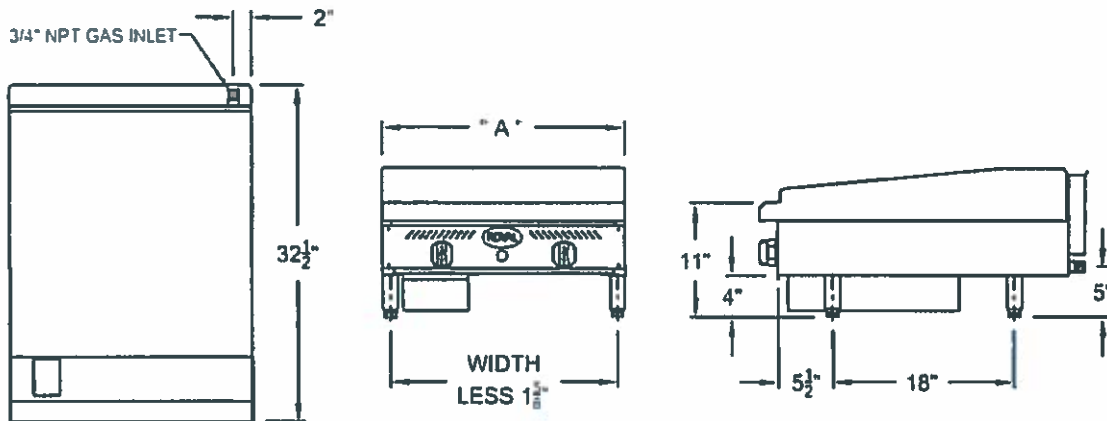

Model Number	Width (A)	Number of Burners	Total BTU	Ship Weight
RMG-12	12"	1	30,000	140 lbs.
RMG-18	18"	1	30,000	165 lbs.
RMG-24	24"	2	60,000	210 lbs.
RMG-36	36"	3	90,000	290 lbs.
RMG-48	48"	4	120,000	370 lbs.
RMG-60	60"	5	150,000	460 lbs.
RMG-72	72"	6	180,000	540 lbs.

Notes:

- Each burner is rated at 30,000 BTU/hr

Gas Connection:

3/4" NPT on the right hand rear of the appliance.

The pressure regulator (supplied) is to be connected by the installer.

Specify type of gas and altitude, if over 2,000 feet, when ordering.

Gas Pressure:

5" W.C.	Natural Gas
10" W.C.	Propane

Clearances:

	Combustible	Non-Combustible
Rear	4"	0"
Sides	15"	0"

Due to continuing product development to ensure best possible performance, these specifications are subject to change without prior notification.

Royal Range of California, Inc.

3245 Corridor Dr. • Eastvale, CA 91752 • (800) 769-2414 • (951) 360-1600

Fax: (951) 360-7500 • www.royalranges.com • sales@royalranges.com

11/19



Item: _____

Quantity: _____

Project: _____

Heavy Duty Stainless Steel Equipment Stands

Heavy Duty Stainless Steel Equipment Stands

Models:	<input type="checkbox"/> RSS-12HD	<input type="checkbox"/> RSS-18HD	<input type="checkbox"/> RSS-24HD	<input type="checkbox"/> RSS-30HD
	<input type="checkbox"/> RSS-36HD	<input type="checkbox"/> RSS-48HD	<input type="checkbox"/> RSS-60HD	<input type="checkbox"/> RSS-72HD



RSS-36HD with optional casters

Standard Features

- Heavy duty stainless steel construction
- Knock down design for easier shipping and field assembly
- Stainless steel undershelf
- One year limited warranty, parts and labor

Options and Accessories

- All welded construction
- 5" swivel casters (set of four - 2 locking) (12"-48" models)
- 5" swivel casters (set of six - 3 locking) (60" and 72" models)



2 YEAR LIMITED, PARTS AND LABOR WARRANTY

Heavy Duty Stainless Steel Equipment Stands

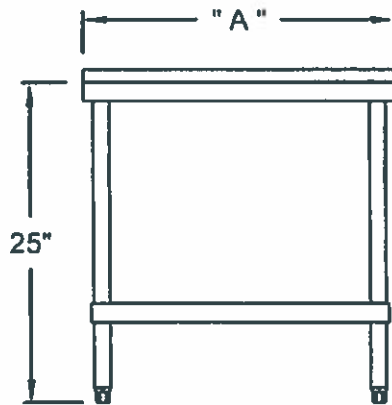

FRONT VIEW

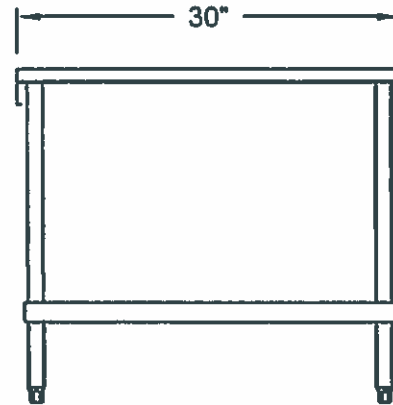

SIDE VIEW

Model Number	Width (A)	Ship Weight
RSS-12HD	12-1/2"	40 lbs.
RSS-18HD	18-1/2"	50 lbs.
RSS-24HD	24-1/2"	60 lbs.
RSS-30HD	30-1/2"	70 lbs.
RSS-36HD	36-1/2"	80 lbs.
RSS-48HD	48-1/2"	90 lbs.
RSS-60HD	60-1/2"	105 lbs.
RSS-72HD	72-1/2"	122 lbs.

Due to continuing product development to ensure best possible performance, these specifications are subject to change without prior notification.

Royal Range of California, Inc.
 3245 Corridor Dr. • Eastvale, CA 91752 • (800) 769-2414 • (951) 360-1600
 Fax: (951) 360-7500 • www.royalranges.com • sales@royalranges.com

11/19



Item: _____

Quantity: _____

Project: _____

50 lb. Deep Fat Fryer

50 lb. Deep Fat Fryer

Models: RFT-50 RFT-DS



RFT-50

Gas Type: Natural LP

Elevation (if above 2000 ft.): _____

Options and Accessories

- Stainless steel tank cover
- Stainless steel side splash guard
- Stainless steel joiner strip
- 48" quick disconnect and restraining cable
- 5" swivel casters (set of four - 2 locking)

Standard Features

- All stainless steel front and sides
- 50 lb capacity stainless steel tank assembly
- 14" x 14" frying area
- Cast iron burners rated at 38,000 BTU/hr each
- Millivolt control system with 100% safety shut off
- Thermostatic control with 200°-400° F range
- Two fry baskets with plastic coated handles for ease of handling
- 1½" full port drain valve
- 6" high adjustable heavy duty legs
- Five year limited (prorated) warranty on S/S tank
- DS - Dump Station
- One year limited warranty, parts and labor



50 lb. Deep Fat Fryer

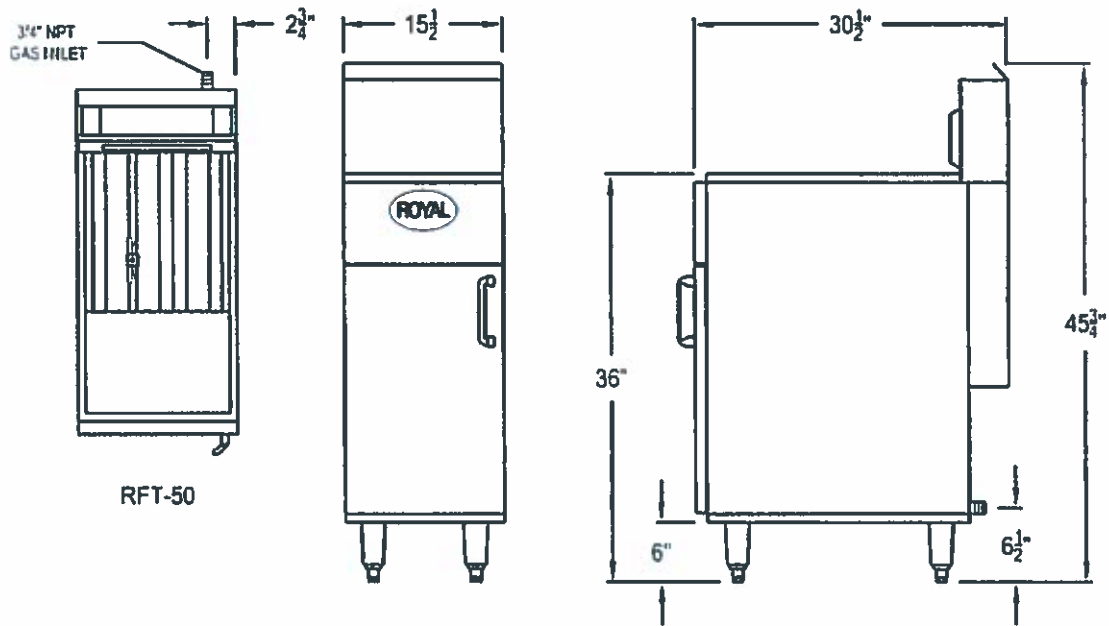

Model Number	Cooking Area	Number of Burners	Total BTU	Ship Weight
RFT-50	14" x 14"	3	114,000	210 lbs.
RFT-DS				130 lbs.

Notes:

- Burner rated at 38,000 BTU/hr each

Gas Connection:

3/4" NPT on the left hand rear of the appliance.
No external pressure regulator required.

Gas Pressure:

4" W.C.	Natural Gas
11" W.C.	Propane

Clearances:

	Combustible	Non-Combustible
Rear	6"	0"
Sides	6"	0"

Specify type of gas and altitude, if over 2,000 feet, when ordering.

Due to continuing product development to ensure best possible performance, these specifications are subject to change without prior notification.

Royal Range of California, Inc.

3245 Corridor Dr. • Eastvale, CA 91752 • (800) 769-2414 • (951) 360-1600
Fax: (951) 360-7500 • www.royalranges.com • sales@royalranges.com

11/19

COUNTY OF AUGUSTA, VA.

BOARD OF SUPERVISORS

JEFFRY A. SLAVEN North River	GERALD W. GARBER Middle River
PAM CARTER Pastures	SCOTT SEATON Wayne
MICHAEL L. SHULL Riverheads	G. L. "BUTCH" WELLS Beverley Manor
	STEVE MORELU South River



TIMOTHY K. FITZGERALD – COUNTY ADMINISTRATOR

AUGUSTA COUNTY GOVERNMENT CENTER

P.O. BOX 590, VERONA, VA 24482-0590

(540) 245-5610 FAX (540) 245-5621

coadmin@co.augusta.va.us

MEMO

TO: Timothy Fitzgerald, County Administrator

FROM: Jennifer Whetzel, Deputy County Administrator 

DATE: August 4, 2020

RE: Strategic Plan

In January, the Board received the attached letter about preparing a strategic plan. I received additional information from Mr. Chandler, who performs such work at a reasonable price (estimated at \$6,500). Please review the attached outline of services. A realistic start time is probably mid- to late September as there are several questions Augusta County must address prior to undertaking this initiative as the following list suggests:

1. What will be the scope of the initiative?
2. Has the full Board expressed support for the initiative?
3. What role will the county staff play in facilitating and implementing the initiative?
4. At present, I envision the initiative will be conducted electronically to be followed by in-person meetings assuming human safety is an issue of concern. Is this acceptable?
5. A reasonable start/finish timeline needs to be set for the initiative. Would I be correct in assuming the Board of Supervisors would want to initiative concluded in time to influence/impact the FY22 county budget process?
6. What questions have I missed?
7. What questions do you have?

Staff recommends that we follow the lead of Mr. Chandler as the facilitator. If the Board has suggestions or questions based on the information included in the agenda packet, please let me know.

COUNTY OF AUGUSTA, VA.

BOARD OF SUPERVISORS

JEFFRY A. SLAVEN
North River

PAM CARTER
Pastures

MICHAEL L. SHULL
Riverheads

G. L. "BUTCH" WELLS
Beverley Manor

GERALD W. GARBER
Middle River

SCOTT SEATON
Wayne

STEVE MORELLI
South River



TIMOTHY K. FITZGERALD – COUNTY ADMINISTRATOR

AUGUSTA COUNTY GOVERNMENT CENTER

P.O. BOX 590, VERONA, VA 24482-0590

(540) 245-5610 FAX (540) 245-5621

coadmin@co.augusta.va.us

MEMO

TO: Timothy Fitzgerald, County Administrator
FROM: Jennifer Whetzel, Deputy County Administrator
DATE: January 14, 2020
RE: Strategic Plan

A Strategic Plan is intended to help the County direct its efforts and resources toward a clearly defined vision for its future. The plan should include benchmarks or milestones that measure the County's progress along the way. This initiative will be institutionalized as a process that is used to guide the organization and its stakeholder partners in making key decisions and tracking progress towards achieving its goals, and to ensure that these goals are aligned upward to the County's Strategic Vision.

While the details of the strategic planning process are to be determined and negotiated with a chosen consultant, a four step process to be considered may include:

- 1) Setting Direction (Environmental Scan and Vision)
- 2) Focusing Efforts (Goals and Priorities)
- 3) Implementation (Countywide/Department Plans)
- 4) Reporting (Progress).

A strategic plan is a "living document" and should undergo periodic review and adjustment to reflect progress towards achievement of goals and/or modifications of goals. As a process and eventual working document, the Strategic Planning process and final document should provide a plan with 3-5, 10 and 20 year horizons to address the following issues:

- Help the County identify what makes Augusta County unique and special, and how the County can position itself to be prepared for the future while still retaining those qualities.
- Transform the conceptual goals of the visioning process into realistic, achievable targets.
- Encourage engagement and spark the interest and excitement of residents, business & property owners, county officials/ administration and staff and others.
- Provide a process that allows general alignment and focus of the Board of Supervisors, County administration, and staff, in addition to citizens, business interests, community groups, etc. to foster a sense of cohesion as to the County's strategic direction.
- Evaluate existing and future public facilities and services; priorities, phasing; help identify how County resources should be allocated and how to maintain customer service levels.
- Generate new ideas and discussion about the built environment, sustainability, sense of place, and the County's overall identity.
- Chart an effective, considered, and innovative course of action for the County's future, setting priorities and maximizing opportunities.

- Serve as a way to organize and prioritize County initiatives and resources to achieve specific goals within a specific period of time, e.g., 3 - 5 year timeframe in the short term, and 10 - 20 year timeframe in the long term, with specific performance measures.
- Recognize economic development potential and ways to diversify the local economy.
- Identify and analyze potential partnerships with other entities; (such as public/public, public/private)
- Plan for fiscal sustainability.

Over the last few months, there have been multiple times that an inquiry has been made about the County's current strategic plan: 1. In reference to the Library's Strategic Plan process; 2. as a guide for the development of a Communications Plan; and 3. in relation to funding large capital projects. The response to the inquiry has been that one does not exist at this time. Guidance in the form of a Strategic Plan would give staff clear direction as to the goals set by the board, allow them to allocate resources to meet those goals, feel a sense of accomplishment as goals are met and focus attentions on the goals versus tasks that fall outside of the Plan.

The above could serve as a scope of work in a Request for Proposal. Staff recommends breaking out the scope of work into options for completion. Pricing for strategic planning services is best achieved through the procurement process, as the scope of work differs among locality contracts. Please add to a future Board agenda for discussion and consideration of moving forward with procuring a consultant.

From: Michael Chandler <rmchan@vt.edu>
Sent: Thursday, April 30, 2020 3:55 PM
To: Jennifer Whetzel <jwhetzel@co.augusta.va.us>
Subject: [EXTERNAL] Augusta County Board of Supervisors 2020-2021 Goal-Setting Proposal - Mike Chandler

Hi Jennifer,

Please view this post as the next step in our conversation focused on engaging the Augusta County Board of Supervisors in a goal - setting process.

As we have discussed, most governing body goal -setting sessions feature an in-person meeting format wherein the members of the governing body participate in a facilitated conversation usually with the goal of crafting a community-centric vision /mission statement which in turn will influence the design of specific initiatives, policies and actions the governing body, by consensus, agrees should be acted upon for the benefit of community residents and community businesses within a specified period of time.

Due to the ongoing Covid 19 crisis, it is my recommendation the process outlined above should be conducted electronically. I am confident this approach will work and would welcome the opportunity to discuss the specific strategy with you, as outlined below, when time permits:

Step One. Chandler will prepare and distribute a written survey to be completed by all members of the Augusta County Board of Supervisors electronically if possible. The survey will be designed to secure Board member input and perspective regarding the following topics:

- a.) **The Board's purpose;**
- b.) **The Board's governance philosophy;**
- c.) **The Board's vision for Augusta County;**
- d.) **The Board/County mission statement;**
- e.) **The board's core values;**
- f.) **Key issues currently facing Augusta County (2020);**
- g.) **Key issues Augusta County will likely face in the future (2025); and**
- h.) **What the Board intends to accomplish (deliverables) in 2020 2021, 2022.**

Step Two. Chandler will tally the survey results without attribution and will forward the summary to all Board members in advance of a 30 minute phone interview Chandler will conduct with each Board member.

Step Three. A summary of the phone interviews interwoven with the survey results will be prepared (draft findings)and sent to all Board members.

Step Four. Upon receipt of the draft findings, Board members will be asked to endorse, modify or reject the findings as presented via a written exercise that will be returned to Chandler.

Step Five. Chandler will tally the Step Four results, inclusive of any unresolved issues, and will forward the summary to all Board members for a final exercise and review.

Step Six. Chandler will prepare and send the draft final report to all Board members for comment and acceptance.

Step Seven. Chandler will make needed adjustments produced by Step Six and will send the final report to all Board members.

Please contact me Jennifer should you have any questions. Thanks, Mike Chandler

COUNTY OF AUGUSTA, VA.**BOARD OF SUPERVISORS**MARSHALL W. PATTIE
North RiverGERALD W. GARBER
Middle RiverPAM CARTER
PasturesG.L. "BUTCH" WELLS
Beverley ManorWENDELL L. COLEMAN
WayneMICHAEL L. SHULL
RiverheadsCAROLYN S. BRAGG
South River**TIMOTHY K. FITZGERALD – COUNTY ADMINISTRATOR****AUGUSTA COUNTY GOVERNMENT CENTER**

P.O. BOX 590, VERONA, VA 24482-0590

(540) 245-5610 FAX (540) 245-5621

coadmin@co.augusta.va.us

TO: Timothy K. Fitzgerald, County Administrator

FROM: Jennifer M. Whetzel, Deputy County Administrator 

DATE: August 4, 2020

RE: Dept. of Housing and Community Development (DHCD) Broadband Grant-VATI 2021

The County advertised a Request for Information for interest from area internet service providers to partner with the County on an application for the 2021 Virginia Telecommunications Initiative (VATI) Grant. Response was received from Rural Broadband Network Services and MGW/Lingo Networks.

DHCD will award \$19 million to eligible applicants to provide last-mile services to unserved areas of the State. The primary objective of the VATI is to provide financial assistance to supplement construction costs by private sector broadband service providers, in partnership with local units of government to extend service to areas that presently are unserved by any broadband provider. The grant will fund up to 80% of the project.

A competitive grant application will be centered on the number of households served, readiness of a shovel-ready project(s), speed of internet service offered and cost of project to the Commonwealth. Deadline for completion of the construction projects is eighteen months from execution of a grant contract. Project areas proposed include: Fort Defiance, Morris Mill, Spottswood, Barren Ridge, Deerfield Valley, and Middlebrook.

The Committee and staff are vetting the proposed projects for overlap with other providers, federal funding in project areas, type of technology offered and ability to offer local match. The Broadband grant sub-committee will provide input for the final grant applications. A public notice has been placed on the DHCD website regarding the applications. The deadline for the application is August 17, 2020.

Over the last four years, the Board has graciously approved funds to match the grants as a requirement of the application. The following is a summary of the proposed projects and local match to be considered.

Rural Broadband Network Services

6 towers with equipment, Total project cost \$2,502,054

Provider offered local match of \$600,000

For ease if you divide the total by 6, the cost of one site would be \$417,000.

Provider match as noted above would be \$100,000 or 24% of total.

MGW/Lingo Networks

Fiber to the home projects in proposal

Project:	Cost:	Match at 30%:	County Share of match-15%:
Deerfield Valley North	\$1,050,000	\$315,000	\$157,500
Middlebrook	\$400,000	\$120,000	\$60,000
Morris Mill	\$2,250,000	\$675,000	\$337,500

The projects are in the final vetting stages and staff will bring a recommendation to the Board on August 12, 2020 for consideration.

COUNTY OF AUGUSTA, VA.

BOARD OF SUPERVISORS

JEFFRY A. SLAVEN North River	GERALD W. GARBER Middle River
PAM CARTER Pastures	SCOTT SEATON Wayne
G. L. "BUTCH" WELLS Beverly Manor	
MICHAEL L. SHULL Riverheads	STEVE MORELLI South River



TIMOTHY K. FITZGERALD – COUNTY ADMINISTRATOR

AUGUSTA COUNTY GOVERNMENT CENTER

P.O. BOX 590, VERONA, VA 24482-0590

(540) 245-5610 FAX (540) 245-5621

coadmin@co.augusta.va.us

MEMO

TO: Timothy Fitzgerald, County Administrator

FROM: Jennifer Whetzel, Deputy County Administrator 

DATE: August 4, 2020

RE: State Recordation Tax

In the 2020 General Assembly Session, legislation was enacted that will alter the manner in which recordation and grantor's tax will be distributed. Attached is, what I believe, the final notice we received from the state regarding sales and recordation estimates. It notes the recordation distribution will change from \$40 to \$20 million. It also notes that there won't be a distribution in FY21 due to the first (now only) \$20 million going to Hampton Roads Regional transit.

Augusta averaged about \$196,000 in recordation over the last 4 years. In FY21, we stand to lose all of this. In future years, if the allocation is cut in half, then we would be short \$98,000. Although the revenue is less than 1% of the County's total revenue budget, \$196,000 could fund 3-4 public safety positions. And why should Augusta County fund Hampton's transit system?

This issue was brought to my attention by Eldon James, our legislative liaison. Attached is a resolution that other localities are adopting to try to bring this matter before the special session of the General Assembly. The resolution is before you for consideration.

RESOLUTION

A RESOLUTION ENDORSING A LEGISLATIVE INITIATIVE
REQUESTING AMENDMENTS TO THE DISTRIBUTION OF STATE
RECORDATION TAX REVENUES TO LOCALITIES

WHEREAS, the Board seeks enabling legislation and amendments to the Virginia Code to accomplish Augusta County's legislative initiatives for the 2020 and 2021 General Assembly sessions; and

WHEREAS, the Board requests amendments to legislation adopted by the Virginia General Assembly during its 2020 session, which resulted in the reduction and elimination of statewide recordation tax revenue distributions to localities for transportation purposes; and

WHEREAS, the Board recognizes that Virginia and its local governments are partners in providing services to our citizens; and

WHEREAS, the Board opposes efforts to reduce the authority and flexibility of the County to govern its citizens and to shift responsibility for shared services solely to localities; and

WHEREAS, the Board opposes the implementation of any new unfunded State mandates or the expansion of any existing unfunded State mandates upon the County and County schools; and

WHEREAS, the Board requests the Virginia Association of Counties (VACo) offer its support for the initiatives contained herein;

NOW, THEREFORE, BE IT RESOLVED by the Augusta County Board of Supervisors on this the 12th day of August, 2020, that the members of the General Assembly representing Augusta County be and they hereby are requested to introduce and support a legislative initiative to amend the State Code regarding the distribution of state recordation tax revenues to localities; and

BE IT FURTHER RESOLVED that staff and the County's legislative consultants will keep the Board apprised of legislative changes and other matters that may adversely impact Augusta County, and its residents and businesses; and

BE IT STILL FURTHER RESOLVED that the County Administrator or his designee will provide a copy of this Resolution to each member of the Augusta County General Assembly Delegation.

RECORDATION AND GRANTOR TAX DISTRIBUTION

During the 2020 session of the General Assembly, legislation was enacted that will alter the manner in which recordation and grantor tax distributions are made to the localities.

Senate Bill 890 revised Section 58.1-816 of the Code of Virginia as follows:

§ 58.1-816. Distribution of recordation tax to cities and counties.

- A. Effective October 1, 1993, ~~twenty~~ \$20 million dollars of the taxes imposed under §§ 58.1-801 through 58.1-809 ~~which that~~ are actually paid into the state treasury, shall be distributed among the counties and cities of ~~this the~~ Commonwealth, *except for counties and cities located in Planning District 8*, in the manner provided in subsection B ~~of this section~~. Effective July 1, 1994, such annual distribution shall increase to ~~forty~~ \$40 million dollars. ***Effective July 1, 2021, such annual distribution shall be \$20 million.***

In addition, also during the 2020 session of the General Assembly, House Bill 1726, beginning in fiscal year 2021, would dedicate the first \$20 million of the annual distribution under Section 58.1-816 to the Hampton Roads Regional Transit Fund (HRTTF). Any remaining amounts would be apportioned and distributed quarterly to the localities outside the Hampton Roads Transportation District.

The Appropriations Act for Fiscal Years 2021 and 2022 in Item 273 – Financial Assistance to Localities distributes \$20 million in each of fiscal years 2021 and 2022. Given that House Bill 1726 would dedicate the first \$20 million of such amount to the HRRTF, there would be no remaining amounts to distribute to the other localities effective July 1, 2020.



• Since 1908 •
Your money. Your community. *Your bank.*

Timberville Office
205 South Main Street
P.O. Box 1111
Timberville, VA 22853
Tel • 540-896-8941
Fax • 540-896-2840
fmbankva.com

June 25, 2020

Mr. Timothy Fitzgerald
Augusta County Administrator
18 Government Center Lane
P.O. Box 590
Verona, VA 24482

As you may be aware, F&M Bank currently owns a banking office at 125 E. Craig Street in Craigsville Virginia. We recently announced our plans to close our retail operations at this facility as of the close of business on July 31, 2020.

We understand that Augusta County has an interest in providing additional library facilities to serve the needs of the Western Augusta / Craigsville community. F&M would be interested in donating the land and building at 125 E. Craig Street to the County for the purpose of either operating a library or providing other County services to the region. Upon conveyance of the property, F&M Bank would like to request that Augusta County lease a suitable space to the Bank on the front of the building with access to lighting, parking and electricity such that the Bank can operate an ATM (Automated Teller Machine) or ITM (Intelligent Teller Machine) at this location to continue to provide the community with banking services.

We request this lease to be extended at no cost to F&M Bank for a period of ten years after the date of the donation. At the end of this ten-year period, the Bank would like the option to lease this space (to include power) with two additional five-year options at a cost of \$175.00 per month.

Thank you in advance for your consideration of this proposal. F&M Bank's Board of Directors feel that this proposal represents an outstanding partnership to continue to support and enhance the quality of life for the community. We look forward to discussing this opportunity further. Please feel free to call me at my office at (540) 896-1743 or on my cell at (757) 810-9072.

Sincerely,

Mark Hanna
President & CEO

Doug Wolfe

From: Atwood, David <david.atwood@vdot.virginia.gov>
Sent: Tuesday, August 4, 2020 10:25 AM
To: Doug Wolfe; John Wilkinson
Subject: [EXTERNAL] Church Hill Lane Extension

Doug/John,

I have attempted an estimate for the 53' extension of Church Hill Lane, 22' wide. It is tough to estimate something with such small quantities, but I have tried to use conservative units for a ballpark idea.

\$500 mobilization
\$3200 21-B stone base (8" x 22' wide)
\$3000 SM-9.5A (2" x 22' wide)
\$300 Sawcut
\$1,000 contingency
\$1,000 demo existing sub-standard pavement
\$2,000 general grading

\$11,000 Total (without engineering and inspection/testing and excludes driveways)

For something like this, you could probably double that total to account for engineering and inspection. So, I would estimate the total burden to be **less than \$25,000**, but I would not be surprised if it could be substantially more or less depending on many factors involved for a small project. Let me know if you have any questions.

David B. Atwood, P.E.
VDOT | Area Land Use Engineer
Harrisonburg Residency Office
3536 North Valley Pike | Harrisonburg, VA 22802
Phone # (540) 434-2587 | Fax # (540) 434-3897



COUNTY OF AUGUSTA
COMMONWEALTH OF VIRGINIA
DEPARTMENT OF COMMUNITY DEVELOPMENT
P.O. BOX 590
COUNTY GOVERNMENT CENTER
VERONA, VA 24482-0590



MEMORANDUM

TO: Board of Supervisors

DATE: July 14, 2020

FROM: John R. Wilkinson, Director of Community Development 

COPY: Timmy Fitzgerald, County Administrator

SUBJECT: Waiver request from the requirement to extend the public street

Brad Long, is requesting a waiver from Section 21-9.1 Streets and Street Connections, from the requirement to construct an extension of Church Hill Lane (Rt. 1318), to VDOT subdivision street standards, in order serve two new dwellings.

All new public or private streets created to serve the lots in any subdivision shall be designed and constructed in accordance with standards and procedures of VDOT subdivision street requirements for addition into the secondary system of state highways.

The applicant stated that he purchased the two building lots and did not know that he would be required to extend the public street at his expense.

Staff has concerns regarding this request as there are numerous existing lots in older subdivisions where the public road stops at the last house constructed years ago, but the rest of the existing lots are fronting along the public right of way. Section 21.9.1 requires the extension of these streets to be built to VDOT standards for acceptance into the State system for road maintenance.

Staff does not support the request as we feel it could set a precedent that would result in the creation of private streets in residential subdivisions that already have public streets maintained by VDOT.

Staunton (540) 245-5700

TOLL FREE NUMBERS

Waynesboro (540) 942-5113

From Deerfield (540) 939-4111

From Bridgewater, Grottoes

Harrisonburg, MI Solon & Weyers Cave (540) 828-6205

FAX (540) 245-5066



1 inch = 180 feet

Regular Meeting, Wednesday, June 10, 2020, 7:00 p.m. Government Center, Verona, VA.

PRESENT: Gerald Garber, Chairman
Pam L. Carter, Vice-Chair
Butch Wells
Michael L. Shull
Scott Seaton
Jeffrey Slaven
Steven Morelli
Timothy K. Fitzgerald, County Administrator
Jennifer M. Whetzel, Deputy County Administrator
James Benkahla, County Attorney
Angie Michael, Executive Assistant (Via Electronic)

VIRGINIA: At a regular meeting of the Augusta County Board of Supervisors held on Wednesday, June 10 2020, at 7:00 p.m., at the Government Center, Verona, Virginia, and in the 244th year of the Commonwealth....

.....

Chairman Garber welcomed the citizens present.

.....

Mr. Morelli led the Pledge of Allegiance.

.....

Ms. Carter, Supervisor for the Pastures District, delivered the invocation.

.....

INFRASTRUCTURE FUNDING

The Board considered a funding request for additional Fire-Rescue staffing in the amount of \$236,191.00.

Funding Source: Pastures Infrastructure	8014-105	\$78,730.33
North River Infrastructure	8013-64	\$78,730.33
Beverley Manor Infrastructure	8011-100	\$78,730.34

Timothy Fitzgerald, County Administrator, stated that there has been a funding request for Fire-Rescue staffing at Churchville Volunteer Fire and Rescue in the amount of \$236,190.38. The Churchville Volunteer Fire and Rescue has been working with Administration, Mrs. Carter, and Mr. Slaven to create 24/7 staffing with career personnel to provide service for Churchville and the western part of the county. The first year of the additional staffing will be covered from Pastures, North River and Beverley Manor Infrastructure accounts. Next year the cost will be included into the normal operating budget. Also included in this request are Lt. Upgrades, bunkroom improvements, and roof replacement. An increase in Revenue Recovery of \$59,800.62 has been accounted for to offset the total cost.

June 10, 2020, at 7:00 p.m.

REVENUE RECOVERY POLICY (CONTD)

Finance recommends that rates for transports be increased. The cost of operating an ambulance has not decreased, it only continues to increase. Rates in surrounding localities have been reviewed as well as Medicare allowable rates. It is recommended that the rate be set at 125% of Medicare allowable. This increase will benefit Revenue Recovery and the volunteer agencies because they get a portion of the rates that come in.

Ms. Carter asked several questions regarding the spreadsheet that Ms. Cook gave to the Board.

Mr. Morelli asked when this would be effective.

Ms. Cook stated that she would like to see it become effective July 1, 2020.

Mr. Shull asked if Augusta County had Mutual Aid with Highland County

Mr. Fitzgerald stated that it was in progress.

Dr. Seaton thanked Ms. Cook for her hard work on the amendments to the policy. He would like to have an update on a yearly basis regarding the policy.

Mr. Wells commended Ms. Cook on her hard work and agrees with Dr. Seaton with getting an annual update on the matter.

Ms. Carter moved, seconded by Mr. Morelli, that the Board approve the Revenue Recovery Policy revisions as presented.

Vote was as follows: Yeas: Garber, Carter, Wells, Shull, Slaven, Seaton and Morelli
Nays: None

Motion carried.

.....

WAIVERS

The Board considered a waiver request from Sally Behm from the requirement to connect to public water and sewer.

Mr. Fitzgerald stated that Sally Behm submitted a waiver request from the requirement to connect to the public water and sewer lines in order to create a new 10.538 acre lot from TM 82-70, located in the Urban Service Area. Ms. Behm has provided an estimate to extend water and sewer lines from a local contractor, but the cost is unreasonable. An easement would be required across the adjoining property to extend the public water and sewer line to her property. The adjoining property owner has declined her request for an easement. The Augusta County Service Authority has stated that this connection would be very difficult without access through the adjoining property. Staff recommends approval of the request.

June 10, 2020, at 7:00 p.m.

CLOSED SESSION (CONTD)

Vote was as follows: Yeas: Garber, Carter, Wells, Shull, Slaven
Seaton and Morelli
Nays: None

Motion carried.

The Chairman authorized the County Administrator/Clerk of the Board to record this certification in the minutes.

.....

BOARDS AND COMMISSIONS

Dr. Seaton moved, seconded by Mr. Shull, that the Board appoint Matthew Egeli to serve on the Augusta County Service Authority. Effective July 1, 2020 and to expire on June 30, 2024.

Vote was as follows: Yeas: Garber, Carter, Wells, Shull, Slaven
Seaton and Morelli
Nays: None

Motion carried.

Dr. Seaton moved, seconded by Mr. Shull, that the Board re-appoint Keith Phillips to serve on the Agriculture Industry Board. Effective July 1, 2020 and to expire on June 30, 2024.

Vote was as follows: Yeas: Garber, Carter, Wells, Shull, Slaven
Seaton and Morelli
Nays: None

Motion carried.

Mr. Morelli moved, seconded by Mr. Shull, that the Board re-appoint Doren Stegura to serve on the Library Board. Effective July 1, 2020 and to expire June 30, 2024.

Vote was as follows: Yeas: Garber, Carter, Wells, Shull, Slaven
Seaton and Morelli
Nays: None

Motion carried.

Mr. Shull moved, seconded by Ms. Carter, that the Board appoint Rebekah Castle to serve as the alternate for the Shenandoah Valley Workforce Development Board Chief Elected Officials Consortium.

Vote was as follows: Yeas: Garber, Carter, Wells, Shull, Slaven
Seaton and Morelli
Nays: None

Motion carried.

.....

Solar Work Session Meeting, Wednesday, June 17, 2020, 5:00 p.m., Government Center, Verona, VA.

PRESENT: Gerald W. Garber, Chairman
Pam Carter, Vice-Chairman
G. L. "Butch" Wells
Michael L. Shull
Scott Seaton
Jeff Slaven
Steve Morelli
Timmy Fitzgerald, County Administrator
Jennifer M. Whetzel, Deputy County Administrator
Leslie Tate, Senior Planner
James Benkahla, County Attorney

VIRGINIA: At a Special Work Session Meeting of the Augusta County Board of Supervisors held on Monday, June 17, 2020, at 5:00 p.m., at the Government Center, Verona, Virginia, and in the 244th year of the Commonwealth....

.....

UTILITY SCALE SOLAR PROJECTS—AUGUSTA COUNTY

Leslie Tate, Senior Planner, gave a brief over view of the vision statement of the Comprehensive Plan and the strategies of growth that drives the vision statement.

Ms. Tate discussed the Comprehensive Plan amendment changes and the Ordinance changes.

Ms. Tate reviewed the next steps to be taken as follows:

- Schedule a presentation on revenue share assessment and siting agreements.
- Staff would recommend the Board direct the Ordinance Committee to evaluate regulations for accessory, ground-mounted residential or commercial solar.
- Option 1: Authorize staff to advertise Comprehensive Plan and Ordinance amendments as discussed.
- Option 2: Have staff present amendments to the Board at a future staff briefing and request authorization to schedule for public hearing.

.....

Chairman
HG-17solarmin 20

County Administrator

Staff Briefing Meeting, Monday, June 22, 2020, 1:30 p.m., Government Center, Verona, VA.

PRESENT: Gerald Garber, Chairman
Pam L. Carter, Vice-Chair
Butch Wells
Michael L. Shull
Scott Seaton
Jeffrey Slaven
Steven Morelli
Timothy K. Fitzgerald, County Administrator
Jennifer M. Whetzel, Deputy County Administrator
John Wilkinson, Director of Community Development
Leslie Tate, Senior Planner
Misty Cook, Finance Director
James Benkahla, County Attorney

VIRGINIA: At an adjourned meeting of the Augusta County Board of Supervisors held on Monday, June 22, 2020, at 1:30 p.m., at the Government Center, Verona, Virginia, and in the 244th year of the Commonwealth....

.....

VDOT ROADS

Don Komara, Residency Administrator, discussed the VDOT status report of June 22, 2020.

The Board accepted the report as information.

.....

ECONOMIC DEVELOPMENT

1) Rebecca Castle, Director of Economic Development, discussed the Economic Development monthly report of May 2020.

The Board accepted the monthly report as information.

- 2) Shamrock AFID Performance Agreement Extension
- 3) Augusta County Disaster Recovery Grant Program

The Board authorized placing on the June 24, 2020 regular meeting agenda.

.....

FIRE AND RESCUE

David Nichols, Fire Chief, discussed the following:

- 1) Fire and Rescue monthly report of April 2020.

The Board accepted the report as information.

June 22, 2020, at 1:30 p.m.

FIRE AND RESCUE (CONT'D)

2) Fire-Rescue Grant Fund application approval.

The Board authorized placing on the June 24, 2020 regular meeting agenda.

.....

DOOMS/CRIMORA DUPONT SETTLEMENT GRANTS

Doug Wolfe, County Engineer, discussed an agreement for maintenance of property.

The Board authorized placing on the June 22, 2020 consent agenda.

.....

MS4-TMDL UPDATE

Mr. Wolfe discussed advertising RFP for Stream Restoration Projects/Nutrient Credits

The Board accepted the report as information.

.....

CRAIGSVILLE ELEMENTARY SCHOOL PLAYGROUND

Timothy Fitzgerald, County Administrator, discussed funding for a playground.

Funding Source: Pastures Infrastructure	8014-106	\$22,128.18
Pastures Parks & Rec Infrastructure	8024-26	\$22,128.18

The Board authorized placing on the June 24, 2020 regular meeting agenda.

.....

MUTUAL AID RESOLUTION

James Benkahia, County Attorney, discussed a resolution authorizing the County Administrator to enter into a Mutual Aid Agreement.

The Board authorized placing on the June 24, 2020 consent agenda.

.....

INFRASTRUCTURE ACCOUNT STATUS

Misty Cook, Director of Finance, discussed additions/deletions to Infrastructure & Recreation Capital Accounts.

The Board authorized placing on the June 24, 2020 regular meeting agenda.

.....

FY2020 & FY2021 BUDGET AMENDMENT-CARES RELIEF FUNDING & SCHOOL CAFETERIS FUND

Ms. Cook discussed appropriations of CARES Relief funding.

The Board authorized placing on the June 24, 2020 regular meeting agenda.

June 22, 2020, at 1:30 p.m.

COURT FEES-ORDINANCE AMENDMENT

Jennifer Whetzel, Deputy County Administrator, discussed an ordinance amendment for court fees.

The Board authorized placing on the June 24, 2020 regular meeting agenda.

PLANNING COMMISSION/PUBLIC HEARINGS:

Leslie Tale, Planner, discussed the following:

- 1) An ordinance to amend Chapter 9. Environment.
- 2) An ordinance to amend Chapter 15. Nuisances, Article I. Noise Control.
- 3) An ordinance to amend Chapter 5. Animals, Article IV. Compensation for Livestock and poultry killed by 5-32. Requirements for compensation.
- 4) An ordinance to amend Chapter 22. Taxation, Article I. In General.
- 5) An ordinance to amend Chapter 22. Taxation, Article II. Real Property Tax. 22-15. Special assessments for agricultural, horticultural, forest or open space real estate.
- 6) A request to amend the Augusta County Comprehensive Plan 2007-2027 and 2014-2015 update by adopting the Stuarts Draft Small Area Plan.
- 7) A request to rezone from Single Family Residential 10 with proffers to General Agriculture approximately 9.85 (TMP 91A(2)3) owned by Trustee of Phyllis Kiser. The Planning Commission recommends approval.

The Board authorized placing on the June 24, 2020 regular meeting agenda.

WAIVERS – NONE

MATTERS TO BE PRESENTED BY THE BOARD

Mr. Morelli stated that zoning for solar should be industrial and the setback should 1,000 feet instead of 200 feet.

MATTERS TO BE PRESENTED BY STAFF

Mr. Fitzgerald discussed the following:

- 1) The first meeting in July is typically cancelled. Mr. Fitzgerald asked for Board direction for the July 8, 2020 Board of Supervisors meeting.

CLOSED SESSION

On motion of Ms. Carter, seconded by Mr. Wells, the Board went into closed session pursuant to:

- (1) **the personnel exemption under Virginia Code § 2.2-3711(A) (1)** [discussion, consideration or interviews of (a) prospective candidates for employment, or (b) assignment, appointment, promotion, performance, demotion, salaries, disciplining or resignation of specific employees];
- (A) Boards and Commissions: Youth Commission, Economic Development Authority, Ag & Forestal Dist., Planning Commission, ACSA, Ag Ind. Brd., Parks & Rec, Library, Recycling, Broadband

REGULAR MEETING AGENDA ITEM NO. 8-09.2

DATE	CHRC#	PAYEE	DESCRIPTION	TOTAL	GENERAL	CENTRALS	MSBC
20200702	12408	ADVANCED TELEPHONE & DATA	SECURITY	3,225.00	-	-	3,225.00
20200702	12409	BAI ACCOUNTING GROUP	DUES	250.00	250.00	-	-
20200702	12410	CLEAR COMMUNICATIONS	VEHICLE MAINT & SUPPLIES	62.00	62.00	-	-
20200702	12411	COUNTY OF AUGUSTA HEALTH	SELF INSURANCE	183,835.00	-	-	183,835.00
20200702	12414	GENERAL SALES OF VA INC	SUPPLIES	311.04	-	-	311.04
20200702	12415	HATHAWAY INC.	SUPPLIES	8,960.00	250.00	-	8,710.00
20200702	12417	JENKINS SECURITY SERVICE	MISCELLANEOUS SUPPLIES	722.69	-	-	722.69
20200702	12418	JIM SNEAD FORD	VEHICLE SUPPLIES	149.33	149.33	-	-
20200702	12419	PROQUEST LLC	BOOKS	2,606.66	2,606.66	-	-
20200702	12421	ROBINSON FARMER, COX, ASSOC	F&R VOLUNTEER AUDIT	60,155.00	60,155.00	-	-
20200702	12422	ROCKINGHAM COOPERATIVE	MISCELLANEOUS SUPPLIES	41.24	41.24	-	-
20200702	12423	TREASURER, VA TECH	EXTENSION OFFICE QUARTERLY SALARY	26,622.38	26,622.38	-	-
20200709	12424	AIRECO SUPPLY, INC	MISCELLANEOUS SUPPLIES	80.96	80.96	-	-
20200709	12425	AUGUSTA PAINT	SITE SUPPLIES	119.97	119.97	-	-
20200709	12426	CAROLINA DIGITAL PHONE	TELEPHONE SERVICE	2,309.35	2,052.00	232.35	25.00
20200709	12428	COUNTY OF AUGUSTA HEALTH	VEHICLE MAINT & SUPPLIES	130.00	130.00	-	-
20200709	12428	COUNTY OF AUGUSTA HEALTH	SELF INSURANCE	237,421.92	-	-	237,421.92
20200709	12431	FISHER AUTO PARTS, INC.	POWER EQUIP SUPPLIES	156.44	156.44	-	-
20200709	12432	GENERAL SALES OF VA INC	JANITORIAL SUPPLIES	997.68	688.88	-	308.80
20200709	12436	KPD, INC. PORT-A-JOHN	RENTAL	500.00	500.00	-	-
20200709	12437	ROCKINGHAM COOPERATIVE	VEHICLE SUPPLIES	72.04	72.04	-	-
20200709	12438	SHEN VALLEY ELECTRIC COOP	ELECTRIC SERVICE	3,336.48	3,075.44	-	261.04
20200709	12439	SOUTHERN ELEVATOR	BLDG MAINT SVC CONTRACT	240.75	240.75	-	-
20200709	12440	STUARTS DRAFT RESCUE	FUEL BENEFITS	1,770.00	1,770.00	-	-
20200709	12441	360 HOME SERVICES LLC	LAWN CARE	7,945.00	7,945.00	-	-
20200716	12443	ATLANTIC TECHNOLOGY	TOWER	450.00	450.00	-	-
20200716	12444	BATTERIES PLUS LLC	SHOP SUPPLIES	53.85	53.85	-	-
20200716	12445	BOBBY'S TOWING SERVICE	REFUSE COLLECTION	71,243.87	69,257.39	-	1,986.48
20200716	12446	CLEAR COMMUNICATIONS	VEHICLE SUPPLIES	224.48	224.48	-	-
20200716	12447	COUNTY OF AUGUSTA HEALTH	SELF INSURANCE	179,715.69	-	-	179,715.69
20200716	12448	DON LARGENT ROOFING INC	MAINTENANCE SHOP ROOF REPLACEMENT	57,814.00	-	-	57,814.00
20200716	12449	EMERGENCY SERVICE SUPPORT	QUARTERLY BILLING SARRS/WFAC	7,848.59	-	-	7,848.59
20200716	12451	GENERAL SALES OF VA INC	JANITORIAL SUPPLIES	779.20	43.80	-	735.40
20200716	12452	H & R CONTRACTORS INC	CUSTODIAL SERVICES	5,979.40	950.00	-	5,029.40
20200716	12454	JIM SNEAD FORD	VEHICLE SUPPLIES	3,099.63	3,099.63	-	-
20200716	12455	LANGUAGE LINE SERVICES	TELEPHONE SERVICE	72.53	36.26	-	36.27
20200716	12456	MSC INDUSTRIAL SUPPLY CO	JANITORIAL SUPPLIES	283.47	162.19	-	121.28
20200716	12457	OFFICE DEPOT	OFFICE SUPPLIES	195.77	164.28	-	31.49
20200716	12458	ROCKINGHAM COOPERATIVE	EASEMENT SUPPLIES	142.19	142.19	-	-
20200716	12459	RXBENEFITS INC	SELF INSURANCE	5,987.90	-	-	5,987.90
20200716	12460	SOUTHERN ELEVATOR	BLDG MAINT SVC CONTRACT	133.75	133.75	-	-
20200716	12461	STUARTS DRAFT RESCUE	REVENUE RECOVERY	63,962.16	-	-	63,962.16
20200716	12462	TACTICAL & SURVIVAL	TACTICAL EXPENSES	2,412.49	2,412.49	-	-
20200716	12463	VALLEY ALLIANCE FOR	CONTRIBUTION	1,000.00	1,000.00	-	-
20200716	12464	WAYNE OXYGEN & WELDING	MISCELLANEOUS SUPPLIES	28.80	28.80	-	-

DATE	CHECK#	PAYEE	DESCRIPTION	TOTAL	GENERAL	CENTRAL	MISC
20200716	12465	XEROX CORP.	OFFICE SUPPLIES	539.33	539.33	-	-
20200723	12466	AIRECO SUPPLY, INC	MAINTENANCE SUPPLIES	550.44	550.44	-	-
20200723	12467	BOBBY'S TOWING SERVICE	MISCELLANEOUS SERVICES	600.00	600.00	-	-
20200723	12468	COUNTY OF AUGUSTA HEALTH	SELF INSURANCE	278,225.91	-	-	278,225.91
20200723	12469	DEMCO INC	LIBRARY SUPPLIES	1,076.45	896.91	-	179.54
20200723	12470	GENERAL SALES OF VA INC	JANITORIAL SUPPLIES	705.74	474.94	-	280.80
20200723	12472	JENKINS SECURITY SERVICE	MAINTENANCE SUPPLIES	122.15	17.00	-	105.15
20200723	12473	JIM SNEAD FORD	VEHICLE MAINTENANCE	814.53	814.53	-	-
20200723	12474	OFFICE DEPOT	OFFICE SUPPLIES	934.07	934.07	-	-
20200723	12475	ROCKINGHAM COOPERATIVE	MISCELLANEOUS SUPPLIES	324.30	153.35	-	170.95
20200723	12476	TIMMONS	PROFESSIONAL SERVICES	3,868.48	-	-	3,868.48
20200723	12477	WASH J & L, INC	CAR WASHES	379.00	379.00	-	-
20200730	12479	ADVANCED TELEPHONE & DATA	TELEPHONE SERVICES	445.00	445.00	-	-
20200730	12480	AUGUSTA PAINT	PAINT SUPPLIES	171.53	-	-	171.53
20200730	12481	CLEAR COMMUNICATIONS	MISCELLANEOUS SUPPLIES & REPAIRS	5,130.29	125.51	-	5,004.78
20200730	12482	COUNTY OF AUGUSTA HEALTH	SELF-INSURANCE	159,442.92	-	-	159,442.92
20200730	12483	DIXIE GAS & OIL CORP.	PROPANE	69.05	69.05	-	-
20200730	12484	EXTINGUISHER SALES & SERV	FIRE EXTINGUISHER INSPECTION	1,185.25	-	-	1,185.25
20200730	12485	FISHER AUTO PARTS, INC.	VEHICLE SUPPLIES	104.04	104.04	-	-
20200730	12487	JENKINS SECURITY SERVICE	MAINTENANCE SUPPLIES	162.78	58.51	-	104.27
20200730	12488	OFFICE DEPOT	OFFICE SUPPLIES	160.72	160.72	-	-
20200730	12489	ROCKINGHAM COOPERATIVE	MISCELLANEOUS SUPPLIES	281.65	281.65	-	-
20200730	12490	RXBENEFITS INC	SELF INSURANCE	186,140.90	-	-	186,140.90
20200730	12491	SAVE ON SP, LLC	SELF INSURANCE	9,443.50	-	-	9,443.50
20200730	12494	360 HOME SERVICES LLC	LAWN CARE	3,915.00	3,915.00	-	-
20200731	12495	BRUBECK LIVING TRUST	RENT	910.00	910.00	-	-
20200731	12496	NEW HOPE RURITAN CLUB	CONTAINER SITE	1,485.38	1,485.38	-	-
20200702	566516	AMAZON CAPITAL SERVICES	OFFICE SUPPLIES	222.06	56.06	-	166.00
20200702	566518	ARCHIVEDSOCIAL INC	MAINT SVC CONTRACT	4,788.00	4,788.00	-	-
20200702	566519	AT&T	TELEPHONE SERVICE	0.47	0.47	-	-
20200702	566520	AUGUSTA COUNTY CIRCUIT	SERVICE FEE	12.00	12.00	-	-
20200702	566521	AUGUSTA COUNTY EDA	CARES GRANT CONTRIBUTION	200,000.00	-	-	200,000.00
20200702	566522	AUGUSTA COUNTY GENERAL	FEE	240.00	240.00	-	-
20200702	566523	AUGUSTA COUNTY SERVICE	FIRE HYDRANT	4,500.00	-	-	4,500.00
20200702	566524	AUGUSTA EQUIPMENT COMPANY	POWER EQUIP SUPPLIES	126.00	126.00	-	-
20200702	566525	BAI COR USER'S GROUP	DUES	400.00	400.00	-	-
20200702	566526	BAI TREASURERS USER GROUP	DUES	600.00	600.00	-	-
20200702	566527	BANKERS INSURANCE LLC	INSURANCE	35,775.00	35,775.00	-	-
20200702	566528	BEVERAGE TRACTOR &	POWER EQUIP SUPPLIES	29.75	29.75	-	-
20200702	566529	BLUE RIDGE COMM COLLEGE	FY21 CONTRIBUTION	5,000.00	5,000.00	-	-
20200702	566530	BOOKPAGE	BOOKS	1,980.00	1,980.00	-	-
20200702	566531	BOUND TREE MEDICAL, LLC	EMS SUPPLIES	364.17	364.17	-	-
20200702	566532	BOYERS 72 DEGREES HEATING	MISCELLANEOUS SUPPLIES	275.00	275.00	-	-
20200702	566534	CAVE TOWN PROPERTIES LLC	RENT	3,604.00	3,604.00	-	-
20200702	566535	CENTRAL_SHEN.CRIMINAL	CSCJTA	58,280.00	58,280.00	-	-

DATE	CHECK#	PAYEE	DESCRIPTION	TOTAL	GENERAL	CENTRAL	MISC
20200702	566536	CENTURION TECHNOLOGIES	MAINT SVC CONTRACT	448.68	448.68	-	-
20200702	566537	CINTAS CORPORATION #394	MISCELLANEOUS SUPPLIES	481.08	481.08	-	-
20200702	566538	CITY OF STAUNTON	GART	4,650.00	4,650.00	-	-
20200702	566539	CITY OF WAYNESBORO, VA	STORMWATER	2,237.78	2,237.78	-	-
20200702	566540	COLUMBIA GAS	NATURAL GAS CONSUMPTION	595.64	595.64	-	-
20200702	566541	COMCAST	TELEPHONE SERVICE	1,090.42	1,090.42	-	-
20200702	566542	COMPLETE CARE OF VA	BLDG MAINT SVC CONTRACT	100.00	100.00	-	-
20200702	566544	DODSON PEST CONTROL	PEST CONTROL	4,446.00	4,446.00	-	-
20200702	566545	DOMINION ENERGY VIRGINIA	ELECTRIC SERVICE	751.40	751.40	-	-
20200702	566546	DRV TECHNOLOGIES INC	MAINT SVC CONTRACT	1,218.00	1,218.00	-	-
20200702	566548	ERIN GRINDZIEJKO-SMITH	GART	206.00	206.00	-	-
20200702	566549	FIRE & SAFETY EQUIPMENT	EQUIPMENT	165.35	165.35	-	-
20200702	566550	FLAGSHIP VISUALS	GART	1,000.00	1,000.00	-	-
20200702	566553	HENRY SCHEIN	EMS SUPPLIES	248.73	248.73	-	-
20200702	566555	ID NETWORKS	MAINT SVC CONTRACT	1,550.00	1,550.00	-	-
20200702	566556	INGRAM LIBRARY SERVICES	BOOKS	564.92	564.92	-	-
20200702	566558	INTEGRATED CUSTOM	MAINT SVC CONTRACT	1,450.00	1,450.00	-	-
20200702	566560	JAMES RIVER EQUIPMENT	POWER EQUIP SUPPLIES	96.22	96.22	-	-
20200702	566561	JOHN WAY	SEIZURE ESCROW	1,605.00	-	-	1,605.00
20200702	566562	KORMAN SIGNS	STREET SIGN SUPPLIES	172.31	172.31	-	-
20200702	566563	LEADSONLINE	MAINT SVC CONTRACT	4,509.00	4,509.00	-	-
20200702	566564	LOCAL GOVERNMENT ATTORNEY	TRAINING	145.00	145.00	-	-
20200702	566565	MARSH & MCLENNAN AGENCY	PROFESSIONAL FEES	916.67	916.67	-	-
20200702	566566	MCCI, LLC	MAINT SVC CONTRACT	10,586.00	9,449.00	1,137.00	-
20200702	566568	MIDWEST TAPE	BOOKS	1,045.34	813.79	-	231.55
20200702	566569	MIDWEST TAPE	BOOKS	30.73	30.73	-	-
20200702	566571	NORTH AMERICAN RESCUE	TACTICAL EXPENSES	1,569.76	1,569.76	-	-
20200702	566572	PLATINUM EDUCATIONAL GRP	TRAINING	500.00	500.00	-	-
20200702	566575	RICE TIRE	VEHICLE MAINT & SUPPLIES	213.00	213.00	-	-
20200702	566577	SECURITY INNOVATIONS, INC	SUPPLIES	154.00	-	-	154.00
20200702	566578	SHI INTERNATIONAL CORP	SUPPLIES	1,312.38	12.39	-	1,299.99
20200702	566579	SHIELDS INVESTMENT CO LLC	RENT	1,950.00	1,950.00	-	-
20200702	566580	SHRED-IT USA	OFFICE SUPPLIES	75.00	60.00	15.00	-
20200702	566581	SOFTWARE UNLIMITED CORP	MAINT SVC CONTRACT	12,207.00	12,207.00	-	-
20200702	566582	SOUTH RIVER IRRIGATION	FOUNDATIONS MAINT SVC CONTRACT	85.00	85.00	-	-
20200702	566583	STRYKER MEDICAL	EMS SUPPLIES	12,500.00	12,500.00	-	-
20200702	566584	SUPPLY ROOM COMPANIES	OFFICE SUPPLIES	77.72	77.72	-	-
20200702	566585	THE DAILY NEWS LEADER	NEWSPAPERS	38.01	38.01	-	-
20200702	566586	TRACTOR SUPPLY COMPANY	STREET SIGN SUPPLIES	9.99	9.99	-	-
20200702	566587	TREAS. OF VIRGINIA	INSURANCE	3,667.00	3,667.00	-	-
20200702	566588	TREASURERS' ASSOC OF VA	DUES	625.00	625.00	-	-
20200702	566589	UNIVERSITY OF VIRGINIA	DUES	2,500.00	2,500.00	-	-
20200702	566590	VA. ASSOC. OF COUNTIES	DUES	15,925.00	15,925.00	-	-
20200702	566591	VA.ASSOC.OF COMMONWEALTHS	DUES	2,800.00	2,800.00	-	-
20200702	566592	IVACORP-VIRGINIA ASSOC.	INSURANCE	747,140.25	723,402.96	23,032.26	705.03

DATE	CHRG#	PAYEE	DESCRIPTION	TOTAL	GENERAL	CENTRAL	MISC
20200702	566593	VALLEY POOL & SPA	POOL SUPPLIES	143.99	143.99	-	-
20200702	566594	VEFGA	DUES	1,008.00	1,008.00	-	-
20200702	566595	VERATHON INC	EMS SUPPLIES	429.26	429.26	-	-
20200702	566596	VERIZON	TELEPHONE SERVICE	121.26	121.26	-	-
20200702	566597	VERTICAL BRIDGE S3 ASSETS	TOWER	3,589.61	3,589.61	-	-
20200702	566598	VIRGINIA SHERIFFS ASSOC.	DUES	3,942.00	3,942.00	-	-
20200702	566599	VMCA	DUES	50.00	50.00	-	-
20200702	566602	WALMART COMMUNITY SYNCB	MISCELLANEOUS SUPPLIES	122.23	122.23	-	-
20200702	566605	WINTERGREEN PROPERTY	LEASE	3,627.84	3,627.84	-	-
20200709	566631	AMAZON CAPITAL SERVICES	SHOP SUPPLIES	1,018.88	1,018.88	-	-
20200709	566633	AT&T MOBILITY	TELEPHONE SERVICE	117.42	117.42	-	-
20200709	566634	AUGUSTA CO-OP FARM BUREAU	MISCELLANEOUS SUPPLIES	44.10	44.10	-	-
20200709	566635	AUGUSTA COUNTY SERVICE	WATER & SEWER	59.81	44.57	-	15.24
20200709	566638	BMS DIRECT	OFFICE SUPPLIES	152.55	152.55	-	-
20200709	566639	BOYERS 72 DEGREES HEATING	MISCELLANEOUS SUPPLIES	531.00	531.00	-	-
20200709	566642	CENTRAL SHEN.CRIMINAL	MATCHING FUNDS	11,160.00	11,160.00	-	-
20200709	566644	CINTAS CORPORATION #394	MISCELLANEOUS SUPPLIES	410.68	410.68	-	-
20200709	566645	COBB TECHNOLOGIES	OFFICE SUPPLIES	0.59	0.59	-	-
20200709	566647	COLUMBIA GAS	NATURAL GAS CONSUMPTION	27.72	27.72	-	-
20200709	566648	COMCAST	TELEPHONE SERVICE	108.35	108.35	-	-
20200709	566649	COMMONWEALTH CARPET	CONTRACT MAINT	175.00	175.00	-	-
20200709	566650	CUSTOM DELIVERIES OF VA	COURIER SERVICE	236.44	236.44	-	-
20200709	566651	DEERFIELD RURITAN CLUB	MOWING	600.00	600.00	-	-
20200709	566652	DEPT.OF MOTOR VEHICLES	VEHICLE SUPPLIES	10.00	10.00	-	-
20200709	566653	DIRECTV	TELEPHONE SERVICE	11.60	11.60	-	-
20200709	566654	DOMINION ENERGY VIRGINIA	ELECTRIC SERVICE	1,082.35	1,082.35	-	-
20200709	566655	EAVERS TIRE	VEHICLE MAINT & SUPPLIES	37.96	37.96	-	-
20200709	566660	FIRE & SAFETY EQUIPMENT	EQUIPMENT	49,771.45	272.76	10,092.83	39,405.86
20200709	566662	HAWK SECURITY SYSTEMS INC	MAINT SVC CONTRACT	145.00	145.00	-	-
20200709	566666	HDIEHL TIRE	VEHICLE MAINT & SUPPLIES	279.79	279.79	-	-
20200709	566667	INGRAM LIBRARY SERVICES	BOOKS	2,275.17	2,275.17	-	-
20200709	566668	INTERSTATE ALL-BATTERY	HAZ MAT	37.98	-	-	37.98
20200709	566669	KNOW INK	VOTING SUPPLIES	125.00	125.00	-	-
20200709	566670	LINEAGE ARCHITECTS PC	SECURITY	4,525.00	-	-	4,525.00
20200709	566671	LOWES COMPANIES, INC.	MISCELLANEOUS SUPPLIES	907.06	804.93	-	102.13
20200709	566672	LUMOS NETWORKS	TELEPHONE SERVICE	1,184.58	1,141.38	43.20	-
20200709	566675	MEDICAL REMOVAL SERVICES	MAINT SVC CONTRACT	455.00	455.00	-	-
20200709	566676	MIDDLE RIVER	SERVICE AGREEMENT	84,202.51	52,124.25	-	32,078.26
20200709	566677	MOBIL SATELLITE	TELEPHONE SERVICE	1,799.88	1,799.88	-	-
20200709	566679	MOTOROLA SOLUTIONS INC	MAINT SVC CONTRACT	153,171.05	153,171.05	-	-
20200709	566680	MT-SOLON VOL-FIRE DEPT.	FUEL BENEFIT	32,852.05	295.00	-	32,557.05
20200709	566681	OCCLC, INC	BOOKS	44.85	44.85	-	-
20200709	566682	PROTEAN	MAINT SVC CONTRACT	2,963.10	2,963.10	-	-
20200709	566683	RAM SOFTWARE SYSTEMS INC	AIM SOFTWARE	700.00	-	-	700.00
20200709	566684	RICE TIRE	VEHICLE MAINT & SUPPLIES	19.95	19.95	-	-

DATE	CHECK#	PAYEE	DESCRIPTION	TOTAL	GENERAL	CENTRAL	MISC
20200709	566885	SEGRA	TELEPHONE SERVICE	2,351.18	2,133.18	218.00	-
20200709	566886	SHEN VALLEY OFFICE EQUIP.	SHREDDER	3,307.00	69.00	-	3,238.00
20200709	566887	SHENANDOAH AWARDS	WEARING APPAREL	259.95	259.95	-	-
20200709	566889	STAPLES BUSINESS CREDIT	OFFICE SUPPLIES	123.60	123.60	-	-
20200709	566890	SUPPLY ROOM COMPANIES	OFFICE SUPPLIES	190.02	190.02	-	-
20200709	566891	THE WASHINGTON POST	NEWSPAPERS	157.60	157.60	-	-
20200709	566892	TOWN OF CRAIGSVILLE	WATER & SEWER	71.00	71.00	-	-
20200709	566894	ULINE	FIXTURES	1,207.33	1,207.33	-	-
20200709	566895	VALLEY CHRYSLER DODGE	VEHICLE MAINT & SUPPLIES	151.73	151.73	-	-
20200709	566896	VALLEY COMMUNITY	FY21 1ST QTR	49,250.00	49,250.00	-	-
20200709	566897	VALLEY POOL & SPA	POOL SUPPLIES	85.38	85.38	-	-
20200709	566898	VEMA	DUES	75.00	75.00	-	-
20200709	566899	VERATHON INC	EMS SUPPLIES	400.00	400.00	-	-
20200709	566700	VERIZON	TELEPHONE SERVICE	202.50	202.50	-	-
20200709	566701	VERIZON WIRELESS	TELEPHONE SERVICE	40.01	40.01	-	-
20200709	566702	VERMONT SYSTEMS, INC	MAINT SVC CONTRACT	6,754.74	6,754.74	-	-
20200709	566706	WHITTINGTON CONSULTING	DUES	200.00	200.00	-	-
20200709	566708	STAPLES BUSINESS CREDIT	JANITORIAL SUPPLIES	47.30	47.30	-	-
20200716	566778	AETNA INC	SELF INSURANCE	78,860.96	-	-	78,860.96
20200716	566780	AMAZON CAPITAL SERVICES	JANITORIAL SUPPLIES	905.49	690.21	-	215.28
20200716	566781	ASHUE KIRACOFE HOWELL	AG & FOREST MEMBER	50.00	50.00	-	-
20200716	566782	ASSOCIATION OF CLERKS	DUES	150.00	150.00	-	-
20200716	566784	AUGUSTA COUNTY SCH BOARD	NATURAL GAS	104.55	104.55	-	-
20200716	566785	AUGUSTA COUNTY SERVICE	WATER & SEWER	932.82	932.82	-	-
20200716	566786	AUGUSTA EQUIPMENT COMPANY	FIRING RANGE	95.67	-	-	95.67
20200716	566787	AUGUSTA HEALTH WORKPLACE	PHYSICAL	40.00	40.00	-	-
20200716	566788	AUGUSTA PETRO COOP INC	FUEL	1,068.84	1,068.84	-	-
20200716	566789	B RANDOLPH ROLLER	AG & FOREST MEMBER	50.00	50.00	-	-
20200716	566790	BEVERAGE TRACTOR &	POWER EQUIP SUPPLIES	369.37	369.37	-	-
20200716	566791	BIBLIOTHECA LLC	MAINT SVC CONTRACT	8,177.44	8,177.44	-	-
20200716	566792	BLOOMAKER	VJIP	5,000.00	-	-	5,000.00
20200716	566793	BOUND TREE MEDICAL, LLC	EMS SUPPLIES	2,009.59	2,009.59	-	-
20200716	566794	BOYERS 72 DEGREES HEATING	MAINT CONTRACT	2,830.00	2,830.00	-	-
20200716	566795	C & S DISPOSAL INC	MAINT SVC CONTRACT	78.00	78.00	-	-
20200716	566799	CHURCHVILLE RESCUE SQUAD	REVENUE RECOVERY	22,004.92	-	-	22,004.92
20200716	566800	CINTAS CORPORATION #394	MISCELLANEOUS SUPPLIES	609.50	609.50	-	-
20200716	566801	CITY OF STAUNTON	WATER & SEWER	1,098.94	1,098.94	-	-
20200716	566802	COM SONICS INC	RADAR	225.40	225.40	-	-
20200716	566803	COMCAST	TELEPHONE SERVICE	612.20	612.20	-	-
20200716	566804	COMPLETE CARE OF VA	BLDG MAINT SVC CONTRACT	100.00	100.00	-	-
20200716	566806	DEERE & COMPANY	FIXTURES	19,639.71	-	-	19,639.71
20200716	566807	DEERFIELD RESCUE SQUAD	REVENUE RECOVERY	1,823.75	-	-	1,823.75
20200716	566809	DOMINION ENERGY VIRGINIA	ELECTRIC SERVICE	9,916.35	8,656.78	1,259.57	-
20200716	566811	EARL REEVES	AG & FOREST MEMBER	50.00	50.00	-	-
20200716	566812	EAVERS TIRE	VEHICLE MAINT & SUPPLIES	20.00	20.00	-	-

DATE	CHECK#	PAYEE	DESCRIPTION	TOTAL	GENERAL	CENTRAL	MSDC
20200716	566813	EDDIE EDWARDS SIGNS, INC.	MISCELLANEOUS SUPPLIES	3,200.00	-	-	3,200.00
20200716	566814	FIELD PRINT	MAINT SVC CONTRACT	201.04	201.04	-	-
20200716	566816	GTP ACQUISITION PARTNERS	TOWER	4,059.78	4,059.78	-	-
20200716	566818	HOWDYSHHELL EXCAVATING	HEARTHSTONE LAKE	969,062.36	-	-	969,062.36
20200716	566819	IDIHL TIRE	VEHICLE MAINT & SUPPLIES	635.00	635.00	-	-
20200716	566820	IMS ALLIANCE	EQUIPMENT	166.30	166.30	-	-
20200716	566821	INGRAM LIBRARY SERVICES	BOOKS	1,411.43	684.09	-	727.34
20200716	566823	JOSEPH ZAPOTOCZNY	AG & FOREST MEMBER	50.00	50.00	-	-
20200716	566824	IUST TECH LLC	OFFICE SUPPLIES	21.85	21.85	-	-
20200716	566826	LAUREN GRIFFIN	REIMBURSEMENT	76.58	76.58	-	-
20200716	566827	LAYMAN, DIENER, &	OFFICE SUPPLIES	21.00	21.00	-	-
20200716	566828	LEAF	OFFICE SUPPLIES	329.16	193.03	136.13	-
20200716	566829	LEXIS NEXIS MATTHEW	LAW BOOKS	759.75	759.75	-	-
20200716	566830	LIONS OF VA DISTRICT 24-C	CONTRIBUTION	658.00	658.00	-	-
20200716	566831	LLOYD ELECTRIC CO OF	SITE SUPPLIES	1,242.00	1,242.00	-	-
20200716	566832	MANSFIELD OIL COMPANY	FUEL	11,399.02	10,886.32	-	512.70
20200716	566834	MERRY MAIDS	CLEANING	220.00	220.00	-	-
20200716	566835	MG-W TELEPHONE	TELEPHONE SERVICE	1,686.96	1,644.79	42.17	-
20200716	566836	MIDDLE RIVER	SERVICE AGREEMENT	1,013,184.25	461,783.25	-	551,401.00
20200716	566837	MOUNTAIN VALLEY TRUCK &	VEHICLE MAINT & SUPPLIES	155.91	155.91	-	-
20200716	566838	MT. SOLON RESCUE SQUAD	REVENUE RECOVERY	23,180.03	-	-	23,180.03
20200716	566840	NEW HOPE RESCUE	REVENUE RECOVERY	7,816.21	-	-	7,816.21
20200716	566841	NEW HOPE TELEPHONE	TELEPHONE SERVICE	358.35	358.35	-	-
20200716	566842	NOLAND COMPANY	WATER & SEWER SUPPLIES	139.59	139.59	-	-
20200716	566843	OAK GROVE THEATER, INC	CONTRIBUTION	2,788.00	2,788.00	-	-
20200716	566845	PRO QUALITY CLEANING	CLEANING	894.00	894.00	-	-
20200716	566847	RICE TIRE	VEHICLE MAINT & SUPPLIES	920.15	920.15	-	-
20200716	566848	RICHARD WILLIAMS	AG & FOREST MEMBER	50.00	50.00	-	-
20200716	566849	RICOH USA	MAINT SVC CONTRACT	160.82	160.82	-	-
20200716	566850	ROBYN WILHELM	REIMBURSEMENT	148.00	148.00	-	-
20200716	566851	SANDI C BATTAGLIA	REIMBURSEMENT	77.94	77.94	-	-
20200716	566852	SECURITY INNOVATIONS, INC	SECURITY	207.75	-	-	207.75
20200716	566854	SHEN VALLEY AIRPORT COMM.	CONTRIBUTION	134,080.00	134,080.00	-	-
20200716	566855	SHEN VALLEY OFFICE EQUIP.	OFFICE SUPPLIES	853.90	705.78	148.12	-
20200716	566856	SHENANDOAH AWARDS	UNIFORMS	119.98	119.98	-	-
20200716	566857	SHENANDOAH VALLEY	PY20-21 CONTR.	75,013.00	75,013.00	-	-
20200716	566858	SHENANDOAH VALLEY TRAVEL	DUES	600.00	600.00	-	-
20200716	566859	SHENTEL	TELEPHONE SERVICE	900.27	900.27	-	-
20200716	566860	SHI INTERNATIONAL CORP	EQUIPMENT	609.54	609.54	-	-
20200716	566861	SHRED-IT USA	OFFICE SUPPLIES	40.00	40.00	-	-
20200716	566862	SITEIMPROVE	MAINT SVC CONTRACT	6,950.00	6,950.00	-	-
20200716	566864	SMOOTH ATHLETICS LTD	UNIFORMS	470.00	470.00	-	-
20200716	566866	STAUNTON ROTARY CLUB	DUES	60.00	60.00	-	-
20200716	566867	STEPHANIE PAYNE	REIMBURSEMENT	99.00	-	-	99.00
20200716	566868	STRYKER MEDICAL	EMS SUPPLIES	2,277.90	-	-	2,277.90

DATE	CHECK#	PAYEE	DESCRIPTION	TOTAL	GENERAL	CENTRAL	MISC
20200716	566869	T&A CLEANING	CLEANING	650.00	650.00	-	-
20200716	566870	THE NEWS VIRGINIAN	ADVERTISING	230.00	230.00	-	-
20200716	566871	TOWN OF CRAIGSVILLE	REIMBURSEMENT	60,395.00	60,395.00	-	-
20200716	566872	TRANSUNION RISK & DUES	DUES	163.00	163.00	-	-
20200716	566873	TREASURER OF VIRGINIA	CORNER	40.00	40.00	-	-
20200716	566874	TREASURER OF VIRGINIA	TELEPHONE SERVICE	27.01	27.01	-	-
20200716	566876	TRIZETTO PROVIDER SOLUTIO	REVENUE RECOVERY	186.30	-	-	186.30
20200716	566877	TSYS HEALTH SERVICES LLC	REVENUE RECOVERY	55.61	-	-	55.61
20200716	566878	TYLER SAVAGE	REIMBURSEMENT	160.76	160.76	-	-
20200716	566879	U.S. BANK	BOND FEE	625.00	-	-	625.00
20200716	566881	VALLEY POOL & SPA	POOL SUPPLIES	163.04	163.04	-	-
20200716	566882	VALLEY TERMITE & PEST	PEST CONTROL	161.00	161.00	-	-
20200716	566884	VERIZON	TELEPHONE SERVICE	6,972.04	6,874.04	98.00	-
20200716	566885	VERIZON	TELEPHONE SERVICE	689.82	689.82	-	-
20200716	566886	VERIZON WIRELESS	TELEPHONE SERVICE	64.29	64.29	-	-
20200716	566887	VERONA CAR CARE INC	VEHICLE MAINT & SUPPLIES	279.46	279.46	-	-
20200716	566888	VIRGINIA STATE POLICE	OFFICE SUPPLIES	30.00	30.00	-	-
20200716	566889	W DOUGLAS RILEY	AG & FOREST MEMBER	50.00	50.00	-	-
20200716	566890	WADE IN CROSS CONNECTION	BLDG MAINT SVC CONTRACT	210.00	210.00	-	-
20200716	566892	WASTE MANAGEMENT OF VA.	REFUSE COLLECTION	4,555.29	3,951.72	603.57	-
20200716	566894	WEST	DATA PROCESSING	224.70	224.70	-	-
20200716	566895	WEYERS CAVE VOL FIRE DEPT	REVENUE RECOVERY	9,124.54	-	-	9,124.54
20200716	566896	WITMER PUBLIC SAFETY	WEARING APPAREL	447.99	447.99	-	-
20200716	566898	XEROX FINANCIAL SERVICES	OFFICE SUPPLIES	1,105.25	966.25	139.00	-
20200716	566899	ZEP SALES & SERVICE	MISCELLANEOUS SUPPLIES	200.27	200.27	-	-
20200716	566900	AUGUSTA COUNTY SERVICE	CARES EXPENSE REIMBURSEMENT	13,058.37	-	-	13,058.37
20200716	566901	LEXIS NEXIS MATTHEW	DUES	150.93	150.93	-	-
20200723	567802	AMANDA IRVINE	JANITORIAL SUPPLIES	31.57	-	-	31.57
20200723	567803	AMAZON CAPITAL SERVICES	MISCELLANEOUS SUPPLIES	1,123.38	247.95	-	875.43
20200723	567804	AT&T	TELEPHONE SERVICE	79.04	79.04	-	-
20200723	567805	AUGUSTA CO-OP FARM BUREAU	MISCELLANEOUS SUPPLIES	926.09	926.09	-	-
20200723	567806	AUGUSTA COUNTY GENERAL	FEE	290.00	290.00	-	-
20200723	567809	BEVERAGE TRACTOR & BUSINESS CARD	MISCELLANEOUS SUPPLIES	81.30	81.30	-	-
20200723	567811	BUSINESS CARD	CREDIT CARD CHARGE	8,912.84	6,973.50	39.98	1,899.36
20200723	567814	CENGAGE LEARNING ACADEMIC	BOOKS	91.17	91.17	-	-
20200723	567815	CENTRAL VIRGINIA ELECTRIC	ELECTRIC SERVICE	192.29	192.29	-	-
20200723	567816	GINTAS CORPORATION #394	MISCELLANEOUS SUPPLIES	324.13	324.13	-	-
20200723	567817	COLUMBIA BUSINESS FORMS	EMS SUPPLIES	402.00	402.00	-	-
20200723	567818	COLUMBIA GAS	NATURAL CONSUMPTION	1,783.79	1,614.17	169.62	-
20200723	567819	COMCAST	TELEPHONE SERVICES	495.80	495.80	-	-
20200723	567820	COMCAST	TELEPHONE SERVICES	2,551.02	2,551.02	-	-
20200723	567821	CORNERSTONE	MAINTENANCE CONTRACT	140.00	140.00	-	-
20200723	567822	DEPT. OF MOTOR VEHICLES	DMV STOPS	2,800.00	2,800.00	-	-
20200723	567823	DOLI/BOILER SAFETY	BLDG MAINTENANCE SERVICE	200.00	200.00	-	-
20200723	567824	DOMINION ENERGY VIRGINIA	ELECTRIC SERVICE	10,616.82	7,905.65	2,711.17	-

DATE	CHECK#	PAYEE	DESCRIPTION	TOTAL	GENERAL	CENTRAL	MDIC
20200723	567825	DOMINION OUTDOORS INC	FIREARMS	1,299.99	1,299.99	-	-
20200723	567826	EAVERS ENT.	MISCELLANEOUS REPAIRS	52.30	52.30	-	-
20200723	567828	GRAINGER	MAINTENANCE SUPPLIES	201.74	201.74	-	-
20200723	567829	INGRAM LIBRARY SERVICES	BOOKS	510.95	400.51	-	110.44
20200723	567830	JUNIOR'S WELDING	HANDRAIL INSTALLATION	4,110.00	-	-	4,110.00
20200723	567834	MIDWEST TAPE	AUDIOVISUAL SUPPLIES	862.03	862.03	-	-
20200723	567836	PAUL HORNSBY & COMPANY	LEGAL SERVICES	13,895.36	13,895.36	-	-
20200723	567837	RECORDED BOOKS, LLC	BOOKS	110.97	110.97	-	-
20200723	567840	ROBYN WILHELM	OFFICE SUPPLIES	126.10	126.10	-	-
20200723	567841	SELECT SPECIALTY PRODUCTS	JANITORIAL SUPPLIES	148.00	148.00	-	-
20200723	567843	STAUNTON VETERINARY CLINI	VET SERVICES	307.04	307.04	-	-
20200723	567844	TREASURER/VFSAAA	MEMBERSHIP DUES	80.00	80.00	-	-
20200723	567845	VECTOR INDUSTRIES INC.	RECYCLING SERVICES	175.00	175.00	-	-
20200723	567846	VERIZON	TELEPHONE SERVICE	53.26	53.26	-	-
20200723	567847	VERIZON WIRELESS	TELEPHONE SERVICE	3,799.29	3,679.26	-	120.03
20200723	567850	WAYNESBORO EDA	GART	35.98	35.98	-	-
20200723	567852	WITMER PUBLIC SAFETY	MISCELLANEOUS SUPPLIES	279.99	279.99	-	-
20200723	567853	YOUNG'S MECHANICAL SOLUTI	MISCELLANEOUS REPAIRS	2,082.87	2,082.87	-	-
20200730	567952	AMAZON CAPITAL SERVICES	OFFICE SUPPLIES	1,091.03	348.50	-	742.53
20200730	567953	AMERICAN OF VIRGINIA INC	MOVING SERVICES	5,392.44	-	-	5,392.44
20200730	567954	APPLE DOOR CO.	MISCELLANEOUS MAINTENANCE	768.10	768.10	-	-
20200730	567955	ATKINS AUTOMOTIVE CO.,INC	VEHICLE SUPPLIES	41.22	41.22	-	-
20200730	567956	ATLANTIC EMERGENCY	VEHICLE MAINTENANCE	8,463.82	8,463.82	-	-
20200730	567958	AUGUSTA COUNTY SERVICE	WATER & SEWER	93.30	93.30	-	-
20200730	567959	BEVERAGE TRACTOR &	MAINTENANCE SUPPLIES	393.49	393.49	-	-
20200730	567960	BLUE RIDGE RESCUE	FIRE FIGHTING SUPPLIES	1,015.47	1,015.47	-	-
20200730	567961	BOUND TREE MEDICAL, LLC	EMS SUPPLIES	131.88	131.88	-	-
20200730	567963	BUILDERS FIRTSOURCE	BUILDING SUPPLIES	62.29	62.29	-	-
20200730	567964	CALEB S KRAMER	LITTER CONTROL SUPPLIES	138.38	138.38	-	-
20200730	567965	CENGAGE LEARNING ACADEMIC	BOOKS	28.78	28.78	-	-
20200730	567966	CENTRAL SHENANDOAH	PY21 ANNUAL ASSESSMENT	55,950.00	55,950.00	-	-
20200730	567967	CHARLIE OBAUGH AUTO GROUP	VEHICLE MAINTENANCE	22.54	22.54	-	-
20200730	567969	CINTAS CORPORATION #394	MISCELLANEOUS SUPPLIES	529.12	529.12	-	-
20200730	567971	COLONIAL AUTO CENTER	VEHICLE MAINTENANCE	483.77	483.77	-	-
20200730	567972	COLUMBIA GAS	NATURAL GAS CONSUMPTION	372.55	372.55	-	-
20200730	567973	COMCAST	TELEPHONE SERVICES	306.12	306.12	-	-
20200730	567974	DAVID W NICHOLS	MAINTENANCE SUPPLIES	15.78	15.78	-	-
20200730	567975	DIGGING SERVICE	CLEAN DRAINAGE CHANNEL	5,060.00	-	-	5,060.00
20200730	567976	DOMINION ENERGY VIRGINIA	ELECTRIC SERVICE	31,197.09	25,030.75	6,166.34	-
20200730	567980	ELECTION SERVICES ONLINE	BATTERIES	1,600.00	1,600.00	-	-
20200730	567981	FIRE LINE EQUIPMENT LLC	VEHICLE SUPPLIES	645.76	645.76	-	-
20200730	567984	GRAINGER	MISCELLANEOUS SUPPLIES	9.16	-	-	9.16
20200730	567985	GREG SCHACHT	MEAL REIMBURSEMENT	56.60	56.60	-	-
20200730	567986	H C EAVERS & SONS, INC	EXCAVATING SERVICES	950.00	-	-	950.00
20200730	567987	HENRY SCHEIN	EMS SUPPLIES	618.00	618.00	-	-

DATE	CHRG#	PAYEE	DESCRIPTION	TOTAL	GENERAL	CENTRAL	MISC
20200730	567989	DIETEL TIRE	VEHICLE MAINTENANCE	67.79	67.79	-	-
20200730	567990	INGRAM LIBRARY SERVICES	BOOKS	2,079.06	2,079.06	-	-
20200730	567991	INTERSTATE ALL-BATTERY	BATTERIES	21.30	21.30	-	-
20200730	567992	JOHN BENNER	TRAVEL REIMBURSEMENT	62.68	62.68	-	-
20200730	567993	JOHNSON CONTROLS FIRE	EMERGENCY REPAIRS	1,428.38	1,428.38	-	-
20200730	567994	KORMAN SIGNS	SGN MATERIAL	206.47	206.47	-	-
20200730	567996	LISA FRACHER	TRAINING SUPPLIES	320.00	320.00	-	-
20200730	567997	LUMOS NETWORKS	TELEPHONE SERVICES	1,157.70	1,118.82	38.88	-
20200730	567998	MARDEN PRESS	OFFICE SUPPLIES	325.00	325.00	-	-
20200730	567999	MARTIA HEVENER	TRAINING SUPPLIES	45.00	45.00	-	-
20200730	568000	MARY KUHAR	TRAINING SUPPLIES	45.00	45.00	-	-
20200730	568002	MEDICAL REMOVAL SERVICES	MAINTENANCE SERVICE CONTRACT	650.00	650.00	-	-
20200730	568003	MIDWEST TAPE	BOOKS	232.38	232.38	-	-
20200730	568005	OPTIMA BEHAVIORAL HEALTH	EAP	740.00	740.00	-	-
20200730	568006	PAUL OBAUGH FORD INC	VEHICLE MAINTENANCE	65.35	65.35	-	-
20200730	568007	PS TAILORING & EMBROIDERY	FIRE FIGHTING SUPPLIES	851.40	851.40	-	-
20200730	568008	RECORDED BOOKS, LLC	BOOKS	260.96	260.96	-	-
20200730	568009	RELX INC. DBA LEXISNEXIS	LAW BOOKS (ONLINE)	300.00	300.00	-	-
20200730	568010	RENEE G PULLEN	TRAINING SUPPLIES	45.00	45.00	-	-
20200730	568011	RICE TIRE	VEHICLE MAINTENANCE	253.85	253.85	-	-
20200730	568013	SHEN VALLEY OFFICE EQUIP.	OFFICE SUPPLIES	90.82	90.82	-	-
20200730	568014	SHENANDOAH AWARDS	MISCELLANEOUS SUPPLIES	1,308.30	405.80	-	902.50
20200730	568015	SHI INTERNATIONAL CORP	COMPUTER SUPPLIES	1,675.92	1,607.86	-	68.06
20200730	568017	SOUTH RIVER IRRIGATION	MONTHLY SERVICE	190.00	190.00	-	-
20200730	568019	SYCOM TECHNOLOGIES	COMPUTER SUPPLIES	7,453.60	4,069.60	-	3,384.00
20200730	568020	THE LIBRARY STORE INC	LIBRARY SUPPLIES	91.28	-	-	91.28
20200730	568021	THE NEWS LEADER	ADVERTISEMENT	3,652.33	3,580.33	72.00	-
20200730	568022	TREASURER OF VIRGINIA	CORONER	20.00	20.00	-	-
20200730	568024	TRINITY TURF INC	NATURAL CHIMNEY GROUNDS	56.00	56.00	-	-
20200730	568025	ULINE	MISCELLANEOUS SUPPLIES	468.72	81.54	-	387.18
20200730	568026	VERIZON	TELEPHONE SERVICE	6,021.90	5,367.35	196.12	458.43
20200730	568027	VERIZON WIRELESS	TELEPHONE SERVICE	6,194.09	5,817.35	23.21	353.53
20200730	568028	VERTICAL BRIDGE 53 ASSETS	TOWER	3,589.61	3,589.61	-	-
20200730	568029	VET. EMERGENCY SERV. INC.	VETERINARY SERVICES	133.98	133.98	-	-
20200730	568031	WALMART COMMUNITY SYNCB	MISCELLANEOUS SUPPLIES	155.75	155.75	-	-
20200730	568033	WITMER PUBLIC SAFETY	MISCELLANEOUS SUPPLIES	758.00	758.00	-	-
20200730	568034	ZOOM VIDEO COMMUNICATIONS	ZOOM SERVICES	999.50	-	-	999.50
20200731	568071	BARSS, MARGARET	JUROR	30.00	30.00	-	-
20200731	568072	HARDING, WANDA	JUROR	30.00	30.00	-	-
20200731	568073	MYERS, DOUGLAS	JUROR	30.00	30.00	-	-
20200731	568074	PACKER, DANIEL	JUROR	30.00	30.00	-	-
20200731	568075	THOMPSON, ARON	JUROR	30.00	30.00	-	-
20200731	568076	WIEGER, JOHN W	JUROR	30.00	30.00	-	-
20200731	568077	WILKES, KEVIN	JUROR	30.00	30.00	-	-

DATE	CHECK#	PAYEE	DESCRIPTION	TOTAL	GENERAL	CENTRAL	MISC
			TOTALS	5,402,022.59	2,331,345.81	48,382.17	3,024,294.61

CONVENE CLOSED SESSION

August 12, 2020

(In) MOTION: _____ SECOND: _____ VOTE: _____

(Out) _____

(Certify) _____

I move that the Board of Supervisors of Augusta County convene in closed session pursuant to:

- (1) the personnel exemption under Virginia Code § 2.2-3711(A) (1)**
 [discussion, consideration or interviews of (a) prospective candidates for employment, or (b) assignment, appointment, promotion, performance, demotion, salaries, disciplining or resignation of specific employees]:
 - a) Boards and Commissions: Youth Commission, Economic Development Authority, Ag & Forestal Dist., Planning Commission, ACSA, Ag Ind. Brd., Parks & Rec, Library, Recycling, Broadband

- (2) the real property exemption under Virginia Code § 2.2-3711(A) (3)**
 [discussion of the acquisition for a public purpose, or disposition, of real property]:
 - a) Augusta County Courthouse

